



# ITS Standardization Activities in Japan

<b>Standardization of ITS</b>	<b>1-2</b>
<b>New Moves in Standardization</b>	<b>3-6</b>
<b>Activities Geared</b>	<b>7-40</b>
<b>for International Standardization in Japan</b>	
● Activities of TC 204 Working Groups	
● Activities of Business Teams	
● ISO/TC 204 International Standards Established	
● Introduction of Related Standardization Activities	
<b>Themes of Standardization</b>	<b>41-42</b>

# Standardization of ITS

Ours is the age of mega-competition. It is necessary for every nation and company to compete in accordance with the same rules in order to maintain fair and sound international transactions. As a mechanism in this regard, “international standards” play an important role. It is not too much to say that each member of the international community cannot obtain confidence from companies and other members for its economic activities in the world without engaging in “standardization activities.”

## Why, then, is “standardization” necessary for international economic activities?

### Reason 1

**WTO’s move toward removal of non-tariff barriers.**

In its efforts for “elimination of trade barriers,” the World Trade Organization (WTO) has set up an “agreement on technical barriers of trade (TBT agreement) and obliged its member countries to coordinate their domestic standards with international standards like ISO on the ground that different standards of each country, and permits and licenses systems may become barriers hampering smooth international logistics.

### Reason 2

**Effects of international standardization**

The role required of standardization has been greater than ever before, ranging from guarantee of interest, safety and convenience to environment protection. The earlier establishment of international standards will make it possible to avoid confusion in the market and improve compatibility among systems and machines, which can be enjoyed by everyone in the world. Industry is expected to benefit from effective use of development costs, reduction in manufacturing costs and an increased share.

### Reason 3

**Ensured market share through leadership in standardization**

Japan has tended to acquire its market share in the manufacturing stage, while entrusting the establishment of standards to other countries. From now on, Japan is required to promote both technological development and standardization in order to survive market competition efficiently. Traditionally, de facto standards have had great influence on the market. In recent years, however, attempts have been made to incorporate them into de jure standards (ISO and other standards by official organizations), making standardization proposals all the more important.

Intelligent Transport System (ITS) is a system to support movement of people and goods in various aspects. Central to ITS are information and telecommunication technologies.

As shown in a figure below, international standardization of ITS is carried out by ISO, IEC, JTC and ITU. In particular, ISO/TC 204 is a leading committee of ITS standardization activities.

Under study at ISO/TC 204 are standardization proposals for (1) system architecture, (2) interface (message set, etc.), (3) framework (data dictionary and message template), (4) performance requirements of a system and (5) test methods. This booklet describes the present situation of ITS standardization activities centering on ISO/TC 204.

### Relations among standardization organizations on ITS

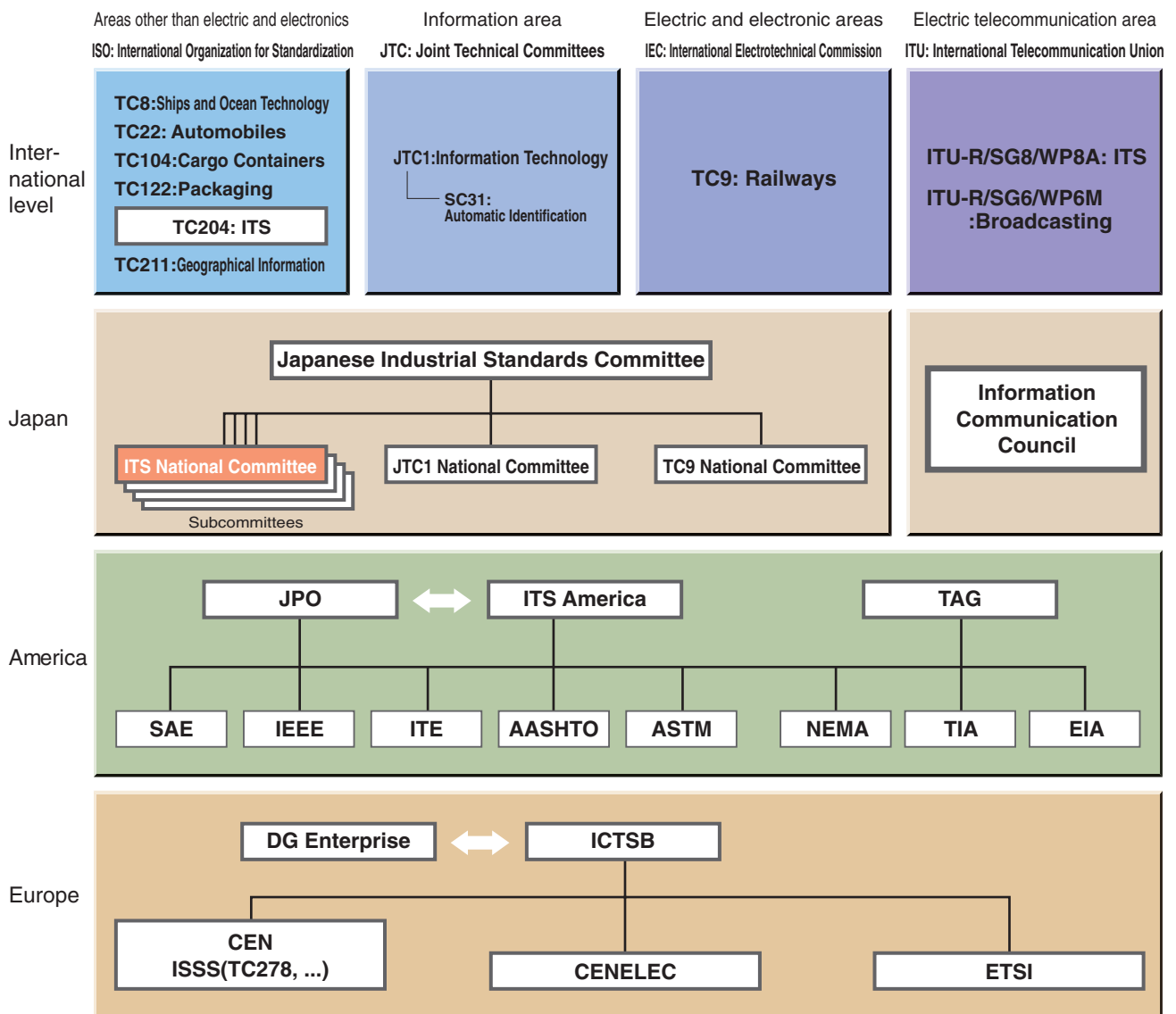

**AASHTO** : American Association of State Highway and Transportation Officials  
**ASTM** : American Society of Testing and Materials  
**CEN** : European Standardization Organization  
**CENELEC** : European Committee for Electro-Technical Standardization  
**DG Enterprise** : Enterprise Directorate General  
**EIA** : Electronic Industries Association  
**ETSI** : European Telecommunications Standards Institute  
**ICTSB** : Information and Communications Technologies Standards Board  
**IEC** : International Electrotechnical Commission  
**IEEE** : Institute of Electrical and Electronic Engineers  
**ISO** : International Organization for Standardization  
**ISSS** : Information Society Standardization System  
**ITE** : Institute of Transportation Engineers

**ITU-R** : International Telecommunication Union-Radio Communication Sector  
**JISC** : Japanese Industrial Standards Committee  
**JPO** : Joint Program Office  
**JTC** : Joint Technical Committee  
**NEMA** : National Electrical Manufacturers' Association  
**SAE** : Society of Automotive Engineers  
**SC** : Sub Committee  
**SG** : Sub Group  
**TAG** : Technical Advisory Group  
**TC** : Technical Committee  
**TIA** : Tracking Industry Alliance  
**WP** : Working Party

# New Moves in Standardization

## ISO/TC 204 Organization (International)

TC 204, a technical committee for standardization for ITS within ISO, was set up in 1992 and went into operation the following year. In ISO, subcommittees (SC) are usually founded under technical committees (TC) and working groups (WG) under subcommittees. Regarding TC 204, working groups are directly under its jurisdiction. Among working groups, some have been suspended or integrated for the ten years since its inception, and now a total of 12 working groups are carrying out its activities. Eight countries serve as lead countries of working groups, and Japan, the U.S. and Germany take charge of two or more working groups.

Working items of TC 204 total 83 as of February 2005. In October 2002, two international standards were established from WG 14 chaired by Japan, the first of its kind. Set up subsequently were one standard from WG 1 in December 2002, two from WG 10 in June 2003, one from WG 11 in December 2003, and one from WG 3, one from WG 5 and one from WG 14 in 2004.

TC 204 has been actively cooperating with other organizations. Take "Data Dictionary and Message Set to facilitate the movement of Freight and its Intermodal Transfer" as an example. It was proposed as PWI at a TC 204 conference in London in May 2002 and approved as NP in March 2003. Several technical committees have been implementing standardization activities in close contact with each other.

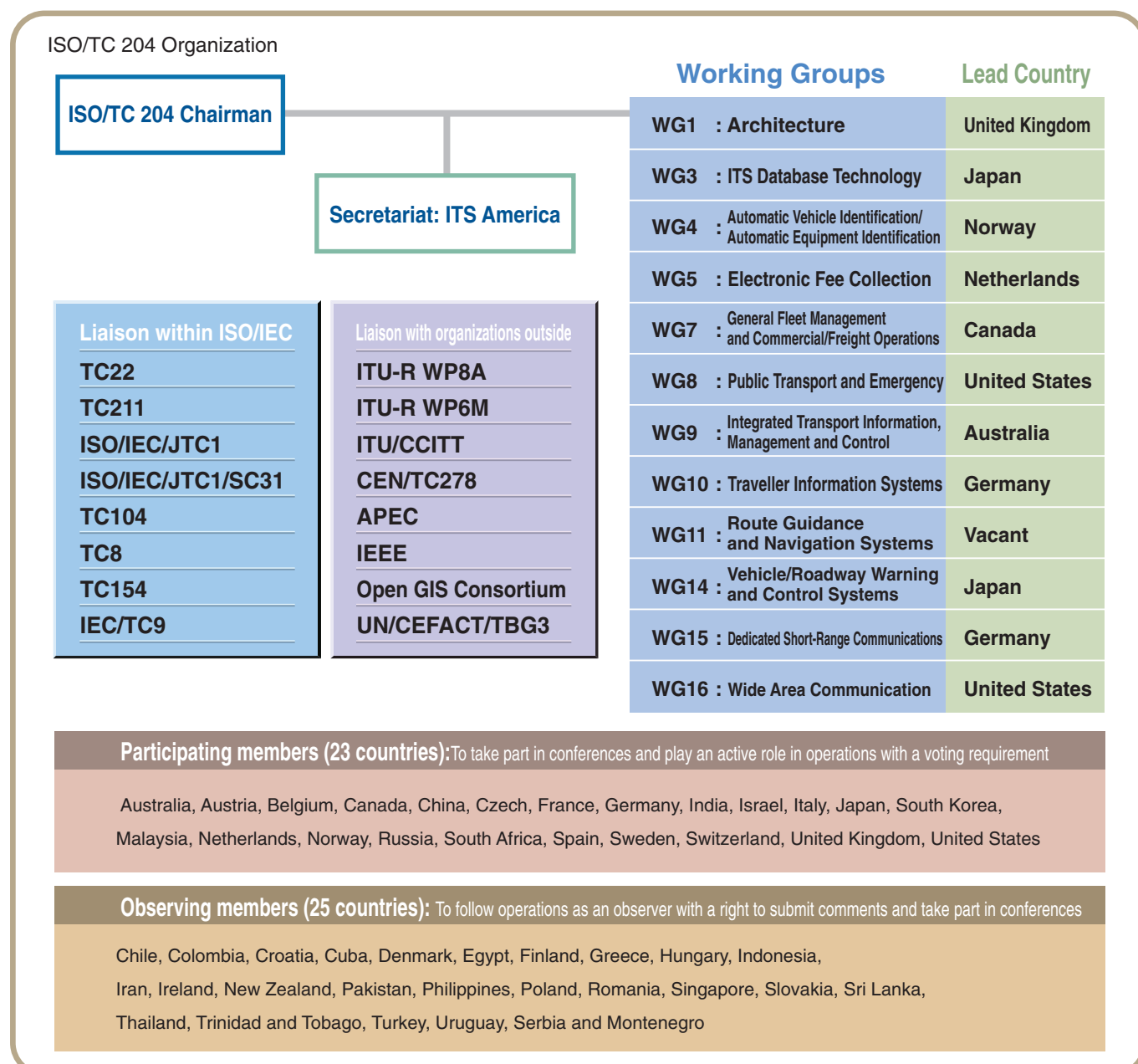

# Activities of ITS National Committee (Domestic)

In Japan, the ITS National Committee serves as a leading organization to study matters handled by ISO/TC 204. The committee has been set up in the Society of Automotive Engineers of Japan, a discussion council for ISO/TC 204. The committee is designed mainly to (1) take swift action in response to changes in the standardization environment, (2) implement standardization activities in accordance with strategies, (3) assist the registration of ITS technologies as JIS and (4) provide related parties with up-to-date information. It has also been actively collaborating with the ITS Info-Communications Forum out of a need to address “traveler information message TPEG using broadcasting-type digital media” proposed by WG 10 and “Wide and Medium-Area Communications Standard CALM” by WG 16. In 2003, an ERI business team was founded and has since been carrying out brisk activities.

## ITS National Committee Organization

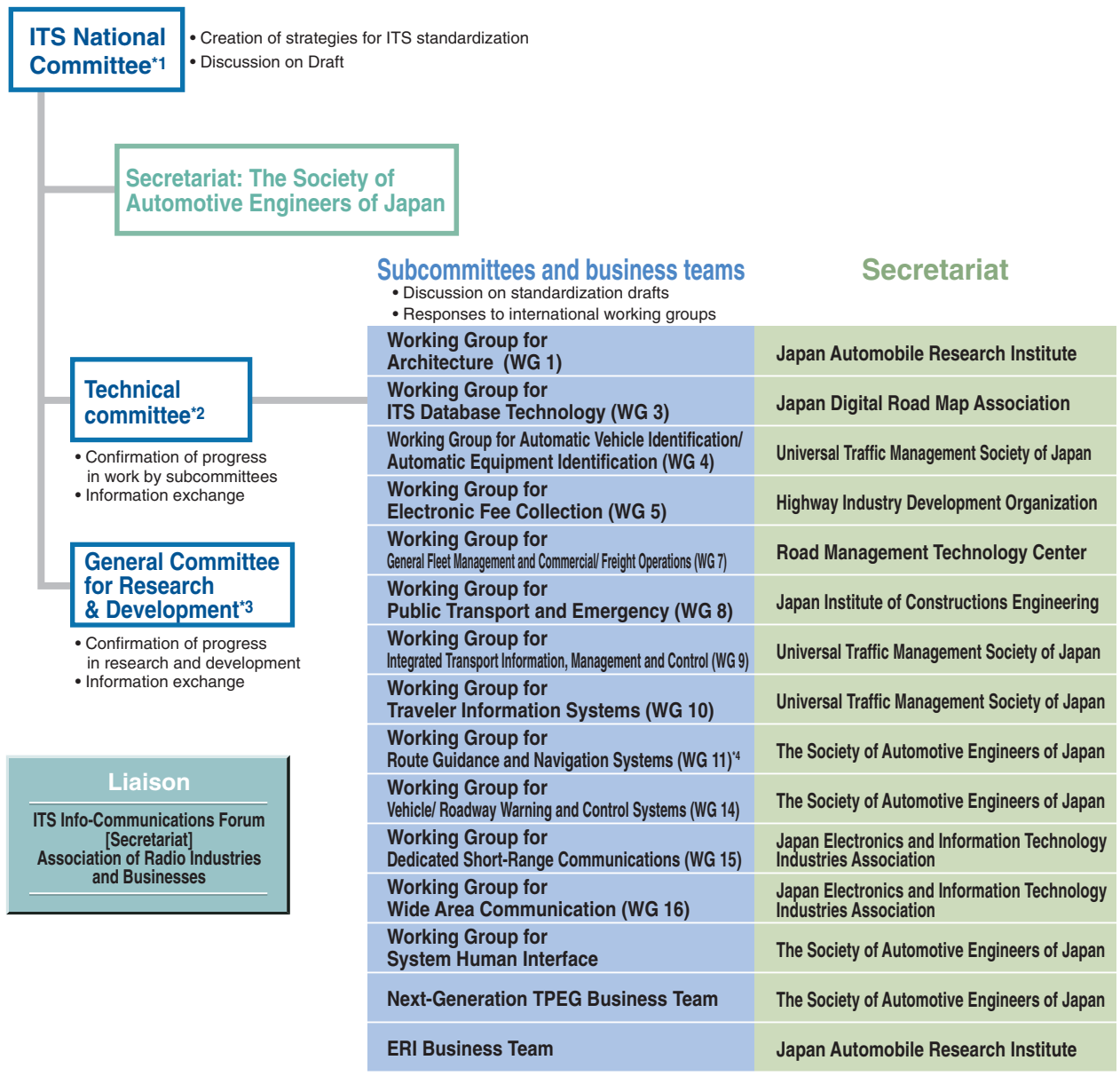

\*1: Comprising 30 members, including manufacturers, consumers and neutral parties

\*2: Comprising some 30 members, including subcommittee chairmen, business team leaders, liaison persons and experts

\*3: Comprising 10-odd members, including subcommittee chiefs and experts, suspended since April 2003

\*4: Suspended since April 2004

### International Relations among Standardization Organizations

ISO is making efforts to establish cooperative relations with related organizations for the purpose of wide use of standards enforced and promoting activities designed to coordinate international standards with laws and regulations of each country. Following are current relations between ISO/TC 204 and other organizations.

#### Cooperation within ISO

TC 204 maintains liaison with TC 22 and TC 211 for standardization because their operations overlap considerably.

#### Cooperation with other international organization

TC 204 effects liaison with the International Electrotechnical Commission (IEC), International Telecommunication Union (ITU) and joint technical committee (JTC) 1 for standardization.

#### Cooperation with CEN

The European Standardization Organization (CEN)/TC 278 has many participating members and is likely to influence discussions at ISO. ISO and CEN keep close cooperation with each other based on the Vienna agreement in order to improve efficiency of standardization.

#### Cooperation with APEC

TC 204 maintains close liaison with the Asia-Pacific Economic Cooperation Conference (APEC)/TPT/ITSWG.

#### Cooperation with WP29

Cooperative relations are maintained with the World Forum for Harmonization of Vehicle Regulations(WP29).

#### Cooperation with WTO

Standardization is promoted with the World Trade Organization (WTO) in accordance with the TBT agreement.

### Standardization of ITS-related JIS and WTO/TBT Agreement

The Japanese Industrial Standards Committee (JISC) (in which Ministry of Economy, Trade and Industry (METI) serves as Secretariat) consists of many national committees and plays central role in standardization activities in Japan. The task of JISC is establishment and maintenance of JIS, administration of accreditation and certification, participation and contribution in international standardization activities, and development of measurement standards and technical infrastructure for standardization.

JISC has actively participated in the international standardization activities as a sole member in Japan, of ISO since 1952, and of IEC since 1953, under the authorization of the Cabinet council (made up of all Ministers).

In 1995, the WTO/TBT agreement went into effect, obliging each member country to work out its domestic standards in accordance with international standards.

In the wake of the effectuation, JISC is promoting coordination of JIS with the international standards. Made public in December 2001 were six TSs: ITS glossary, reference architecture Part 1 through 4, and on-board system architecture. Announced in March 2002 were two JIS—the adaptive cruise control systems and the forward vehicle collision warning system. The year 2003 saw the notification regarding the JIS of the “road vehicles—the map data physical storage format for car navigation systems” (commonly known as KIWI) related to WG3. Also underway in 2004 was the TS of the “evaluation method for driver acceptance” of WG14. A JIS Drafting Committee is set up under the ITS National Committee, if the need arises.

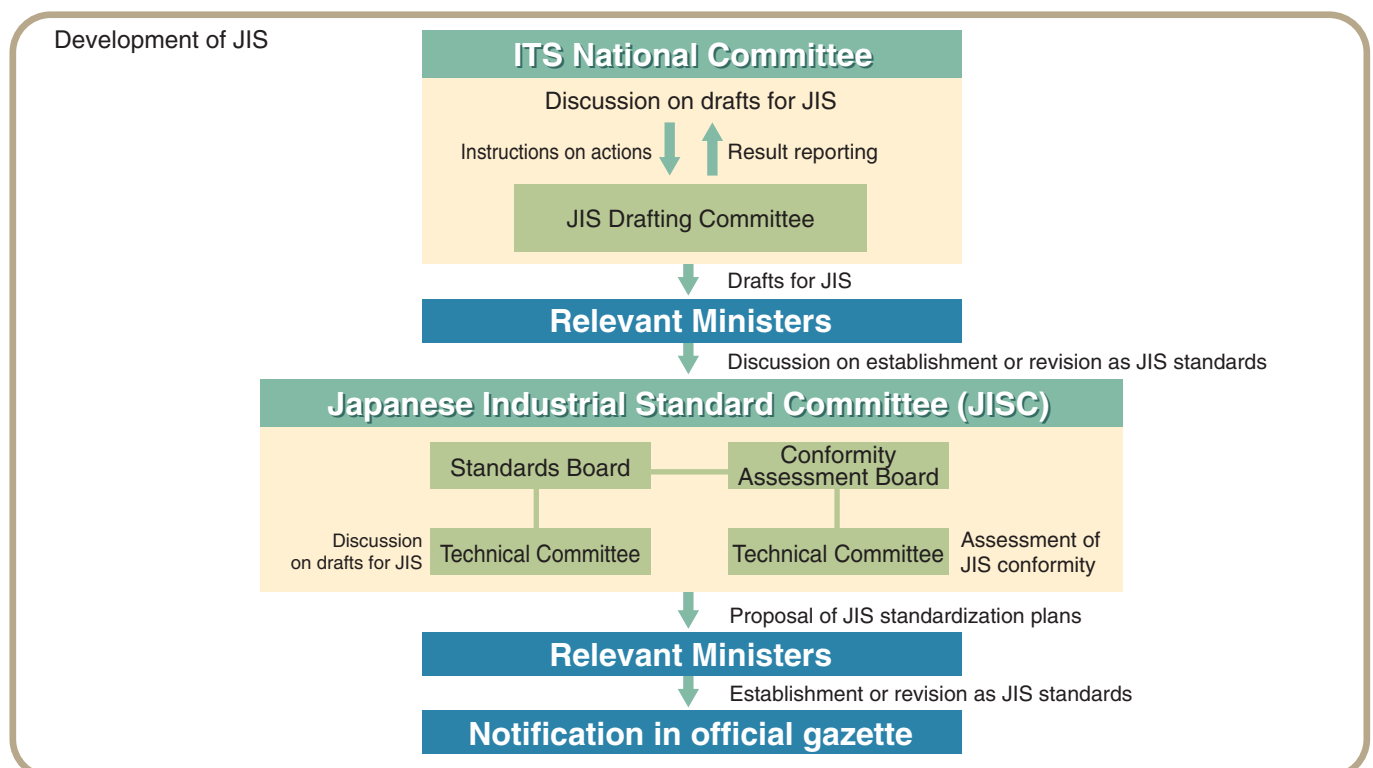

## Procedures for establishment of ISO standards

ISO/TC 204 has been carrying out numerous standardization activities related to ITS themes. These themes are discussed and voted in accordance with standardization establishment rules specified in the ISO/IEC Directives to enact standards.

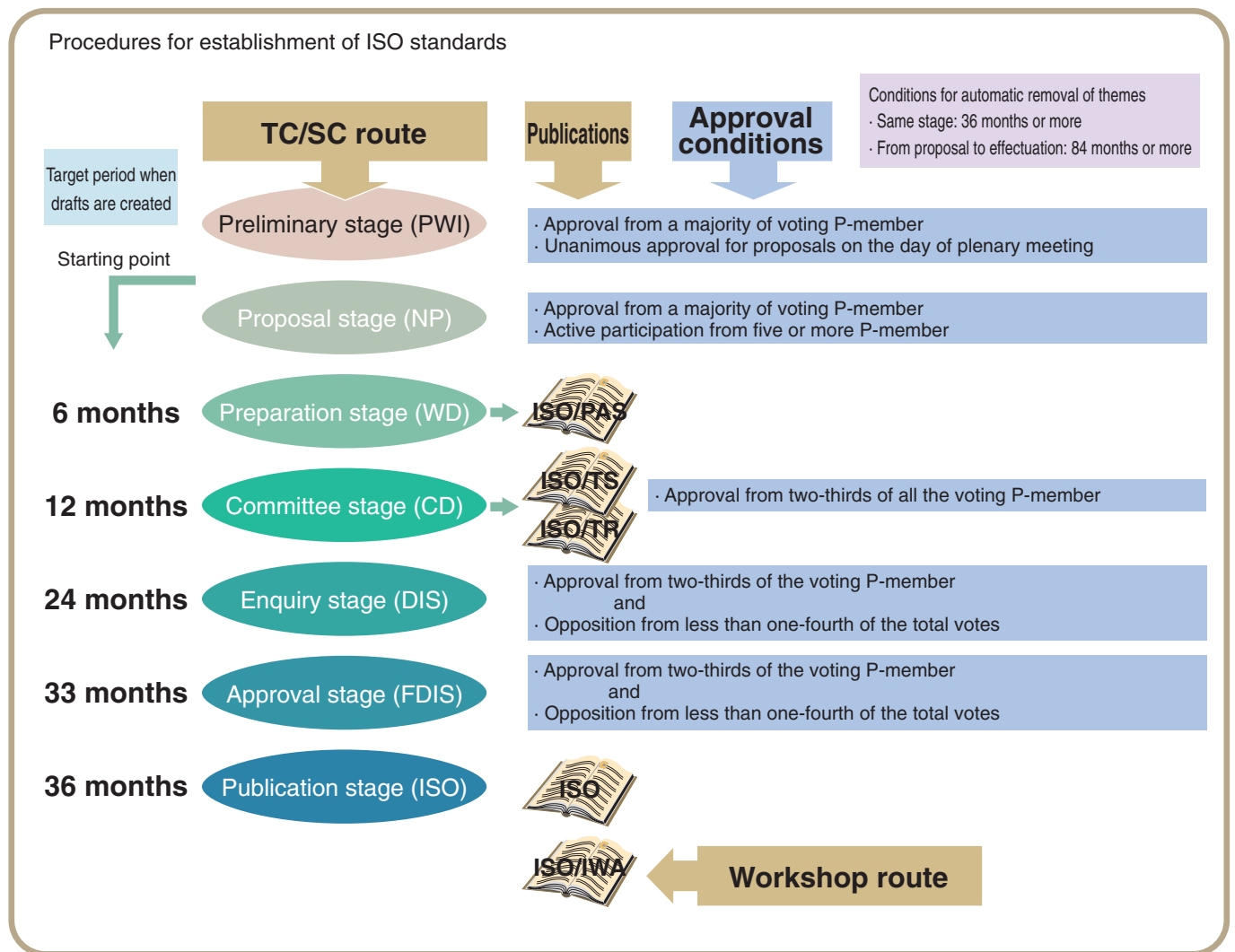

## Publications of ISO

ISO can publish ISO/PAS through WG agreement, and ISO/TS or ISO/TR through TC/SC agreement with a view to early public announcement of standard documents (TC/SC route on the map above). ISO/PAS is medium-term specifications of international standards in the previous stage. It does not meet requirements. ISO/TS is a semi document that is expected to obtain agreement of international standards. ISO/TR is a collection of technical data different from international standards. If an agreement is reached on technical documents through workshop designed to meet standardization needs in new technical fields or fields with no professionals, instead of a conventional TC/SC route, it can be published as products of ISO (ISO/IWA). (Workshop route above)

## Procedures for simplification of ISO standard establishment

Usually, ISO standards are established through six stages (NP through ISO) shown in the above figure. Some of the stages can be omitted by satisfying conditions specified in the ISO/IEC Directives. Approved at present are (1) NP voting to CD or DIS, (2) WD to DIS, (3) DIS to ISO (no FDIS), (4) external documents to DIS voting (Fast-track procedure), and (5) directly to FDIS.

# WG 1: Architecture

ITS is a large-scale system with many application areas, and a large number of people are involved in its development for a long time. Therefore, it is important to establish architecture to ensure interoperability, compatibility and expandability. WG1 is preparing standards related to information and methods to be shared within the ITS sector—common use of terms, sharing of concept and unification of methods to describe documents and data.

List of WG 1 work items (as of February 2005)

	Standardization themes	ISO number	Content
1	Glossary of ITS standards	TR14812	A simple list of semantic descriptions explaining standard terms and the abbreviations in the ITS sector
2	Reference model architecture	TS14813	To specify fundamental services, core architecture and descriptive requirements for architecture, to be referenced in the development of new architecture and comparison of different architectures
3	Requirements for ITS central data registry and data dictionaries	ISO14817	To define requirements for the framework, formats, and procedures used to define information and information exchanges within the ITS sector
4	Use of XML for ITS standards, data registry and data dictionaries	NP/CD24531	To stipulate rules in using XML for ITS standards, data registry and data dictionaries
5	Use of CORBA for ITS standards, data registry and data dictionaries	DTR24532	To stipulate rules in using CORBA for ITS standards, data registry and data dictionaries
6	Use of UML for ITS standards	PWI	To stipulate rules and guidance in using UML for ITS standards, data registry and data dictionaries
7	Use of web services for ITS	PWI	To stipulate guidance for use of web services designed to support collaboration among Internet-based systems
8	Procedure for developing ITS deployment plans utilizing system architecture	PWI	To describe the procedure of developing ITS deployment plans utilizing ITS system architecture

## Activities

Reference model architecture (14813: six parts, such as fundamental services and core reference architecture) had been published as TS by 1999. In November 2001, work was launched jointly with IEEE on the development of requirements for data registry intended to promote data sharing, and it resulted in an international standard in December 2002.

Current major issues are development of standards to ensure compatibility among various fields by preparing rules for the usage of XML, CORBA and UML in ITS areas; formation of standard procedures for preparation of ITS deployment plans; revision of already-published reference architecture; and promotion of implementation of ITS data registry established as an international standard.

## ITS reference model architecture (TS 14813)

System architecture is, in a sense, a conceptual design of a whole system. In establishing ITS, a large-scale and long-term system, system architecture is important to make all the people concerned share a picture of a whole system and to ensure interoperability, compatibility and expandability of a system. The ITS reference architecture has been established to serve as reference materials for architectural development in various countries and WGs in TC204, and as a reference model for comparison of different architectures, such as the OSI layer model.

TS 14813 consists of six parts as follows. Of the six parts, JIS/TR corresponding to Parts 1, 2, 5 and 6 has been publicly announced as D 0002. Underway at present is the revision of parts 1 and 6. Then, Parts 2 and 5 may be revised.

TS14813

Part	Titles	Outline
1	ITS fundamental services	Definition of 32 fundamental services
2	Core reference architecture	Description of abstract object-oriented system architecture
3	Example elaboration	Description of a specific example of reference architecture with emphasis on traffic management
4	Reference model tutorial	Explanation of basic terms and modeling views in defining object-oriented architecture
5	Requirement for architecture description	Terms and forms to be used for documentation or reference of architecture
6	Data presentation in ASN.1	Description of ASN.1 to be used for normal syntax notation



## Requirements for ITS central data registry and data dictionaries (ISO 14817)

It is extremely important that the data with the same contents have the same name and those with different contents have different names, in terms of increased efficiency and reliability of system development through common use of data. But it is easier said than done. Data dictionaries are designed to manage definitions and expressions of data subject to common use. Under this standard (ISO 14817), it is assumed that a data dictionary will be prepared for each functional area. A mechanism aimed to register and manage interdisciplinary data used among various areas is called data registry. In developing a new system, it will be efficient to study the use of common data stored in data registry.

Elements of data dictionaries (example)

Class Name	event information	
Data element name	Object involved in accident, eventAccidentObject	
Identification code	900043	
Definition	Object involved in accident is described in codes. Running vehicle (1), Protection wall (2), Median strip (3), Bank (4), Others (99)	
Data representation	data type	eventAccidentObject, :: =ENUMERATED
	Value domain	1..99
Registration status	recorded	
Registration date, renewal date	YY/MM/DD	
Last modifier	(Name of that person)	

## Use of CORBA, XML and UML

TC 204 uses UML and ASN.1 as standard languages to describe information models and data contents subject to standardization. In recent system implementations, CORBA and XML have been increasingly used to send and receive data between subsystems. Except for ASN.1, language specifications are established as a consortium standard. ISO/IEC is also promoting the establishment of related standards.

Usage of CORBA, XML and UML

Language	Full spelling	Organization in charge of a language	Related international standards
ASN.1	Abstract Syntax Notation One	ISO	ISO/IEC 8824, 8825
CORBA	Common Object Request Broker Architecture	OMG(Object Management Group)	ISO/IEC 14750
XML	eXtensible Markup Language	W3C(The World Wide Web Consortium)	ISO/IEC TR22250
UML	Unified Modeling Language	OMG(Object Management Group)	ISO/IEC DIS19501

All the above languages have their own advantages and should be used in the right places, while rules for appropriate use must be worked out in order to guarantee compatibility in the whole ITS. WG1 has launched work to compile necessary rules and guidance in using each language in standard documents and data registry.

## Procedure for developing ITS deployment plans utilizing ITS system architecture

Architecture describing a whole picture of ITS has been formulated in such leading countries and regions as Europe, Japan and the United States, followed by the establishment of similar architecture in Australia, China, South Korea and Taiwan. In the next phase, Europe, Japan and the United States prepared standard procedures for ITS deployment, such as selection of services to be implemented, development from logical architecture to physical architecture and sharing of roles among related entities, on the basis of system architecture.

This work item is designed to sort out knowledge resulting from these preceding activities, to create documents of standard procedure for developing regional ITS deployment plans utilizing system architecture and thereby to contribute to activities of countries and regions planning to deploy ITS. This work item was approved as PWI at a TC 204 plenary meeting in October 2004, and study is underway on drafts for the purpose of NP proposal.

# WG 3: ITS Database Technology

Many of the ITS services use geographical information, which is increasingly gaining in importance against the background of ever-growing car navigation services. In other services, geographical information is often necessary to give information and instructions. WG 3 is studying standard plans for interface to exchange geographical information, considering various situations.

List of WG 3 work items (as of February 2005)

	Standardization themes	ISO numbers	Contents
1	Geographical data file	ISO14825	Standard for data exchange of geographical database serving as the basis for geographical data used for navigation
2	Expanded geographical data file	WD22953	Expanded updated version of geographical data file
3	Physical storage format	DTS20452	Standardization of data storage methods, such as CD-ROM used for navigation
4	Map distribution	PWI	Communication format to transmit map data
5	Methods for location reference	CD17572	Standardization of location reference in case of information exchange between different applications and between geographical database
6	API standard	PWI	Standardization of methods for access to data by application programs like navigation

Perspective of work items of WG 3

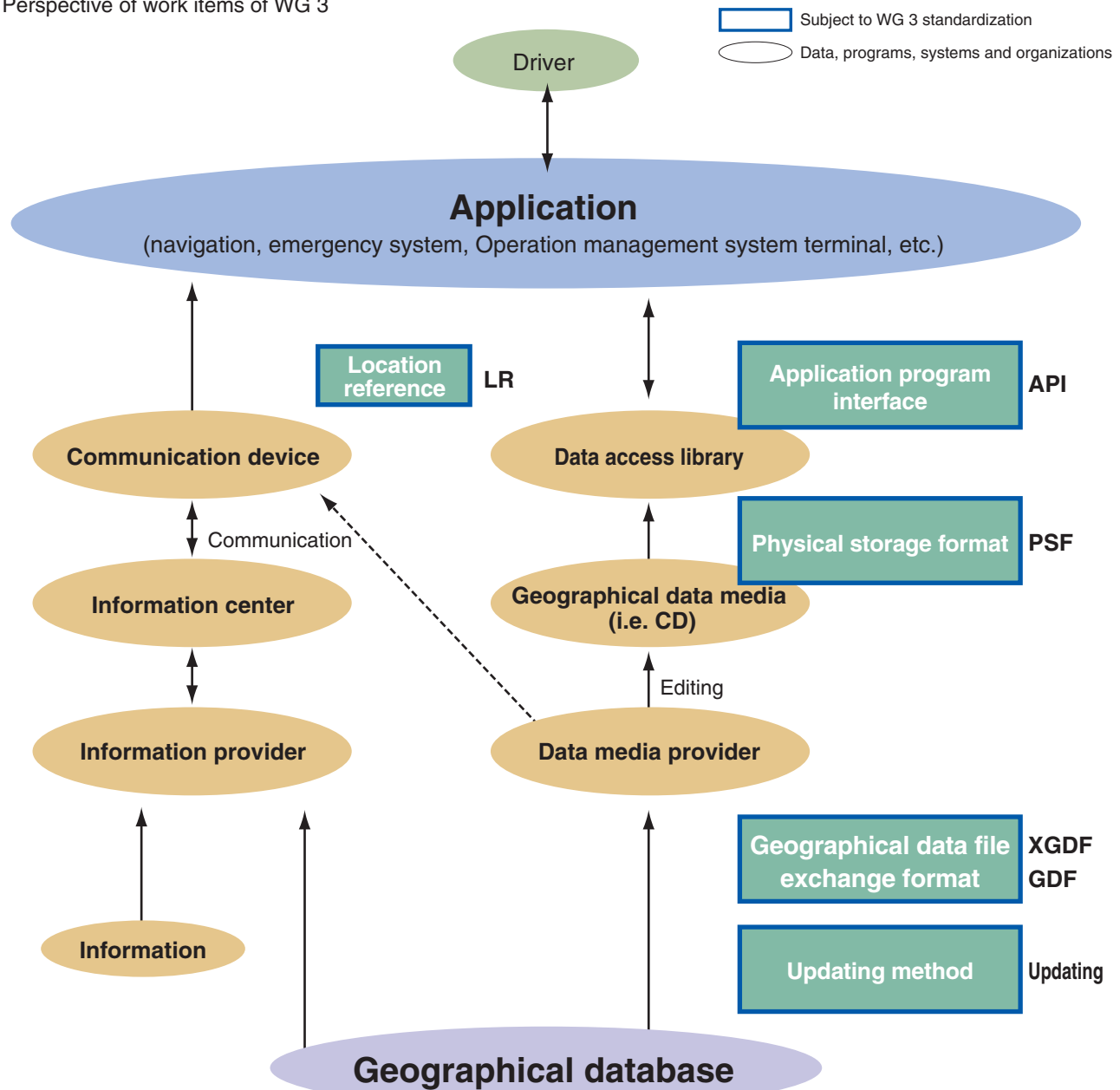

## Geographical data file (ISO 14825) and expanded geographical data file (WD 22953)

This is the standard for data exchange of geographical database serving as the basis for road maps used for navigation. As the file is not used directly for navigation, emphasis is placed on ease of editing—genre-by-genre compilation of data—rather than compactness and speed in comparison with physical storage. In other words, priority is given to the production side. Regarding XGDF, however, consideration will also be given to methods for providing information.

As for GDF, work was implemented in consideration for the Japan digital road geographical database standard and others, on the basis of CEN-DGF studied in Europe. Thanks to the preceding work for standardization by CEN, work went relatively smoothly, and GDF was announced as IS in February 2004.

The entire volume of GDF is huge. As discussions went on, new ideas were proposed, requiring a lot of time to complete drafts, though work on GDF went smoothly, compared with other items. In the wake of the completion of WG drafts, study on the next standard was launched immediately, and a new PWI was approved at a TC conference in November 2000. The purpose was to revise GDF and accommodate the latest developments in information exchange, such as the Internet. The work entered the NP phase after compiling requests for improvement.

Discussions on XGDF got underway with themes on required performance and models. Japan for its part has made a proposal based on KIWI+, a new standard of the Japan Digital Road Map Association. KIWI+ has been evolved from KIWI, which has been widely used in Japan and served as a basis for proposed physical storage. Emphasis is placed on structures capable of time management. It has been decided to use UML for a concept model. UML is adopted by TC 211, which handles geographical information comprehensively. Efforts have been made for coordination with TC 211.

## Location referencing methods (CD 17572)

This is subject to methods for location referencing when information is exchanged between different applications and geographical database. It is designed to find out location on a different map database when traffic information is exchanged between systems.

Activities in this field were stalled for some time because the results of demonstration experiments in Europe and the United States were not available. During the stalemate, a need for standardization of general-purpose LR was growing sharply, as the information community was moving rapidly toward standardization. In 2000, WG 3 launched discussions on drafts for three methods; Profile 1 (Pre-coded Location referencing: a method premised on regulation in a system, including a method using pre-coded location tables); Profile 2 (Geographic Object Referencing: a method through coordinates (required) and descriptors (optional)); and Profile 3 (Explicit Location Referencing: a method with consideration for the mobile Internet, such as XML). Profile 1 has been completed, while Profile 2 is in the phase of waiting for results of coordination in Europe. Profile 3 has been canceled due to no specific proposals.

In accordance with new rules of ISO, LR was automatically expired in September 2001 because it had not entered the CD phase. WG 3 for its part proposed a new NP to TC 204 in order to continue work and complete standard plans. In January 2003, it was approved as NP, and standardization work is still underway.

## Other work items

The member countries failed to reach an agreement in discussions on drafts for physical storage (NP 14826), API standard (NP 17267) and updating (NP 17517), and were compelled to finish work on these items in compliance with the new ISO rules.

As for NP 14826, NP has been proposed and approved to register agreements on standardization as official documents, and circulation of CD comments of TS has been approved with its preparation underway. A new PWI was approved for NP 17267 in November 2003, and interface with priority given to applications is likely to be studied.

## New proposals

Under discussion nowadays are updating of map data and in some cases transmission of map data, if a need arises, in the navigation field. Japan proposed studying format standards to address the movement, and PWI was approved at a TC conference in October 2004.

**API** : Application Program Interface  
**GDF** : Geographic Data File  
**LR** : Location Reference  
**PSF** : Physical Storage File  
**XGDF** : Extended Geographic Data File  
**UML** : Unified Modeling Language

**KIWI+** : Simple Topology & Special Temporal  
- Open Database Schema

This is a pet name of the public implementation-level database structure which handles time and space information uniformly with the implication-type phased description method. In this structure, the KIWI format proposed from ISO/TC204/WG3.2 with a view to use for car navigation and other applications is combined with the DiMSIS (time-space information system) data structure.

# WG 4: Automatic Vehicle Identification/Automatic Equipment Identification

WG 4 is in charge of standardization of items necessary for interoperability between systems regarding AVI/AEI, an automatic identification system for vehicles and equipment through such simple media as tags. First, it discussed standardization themes on overland transportation like trucks, and then added an intermodal AVI/AEI system as a theme. Initially, WG 4 did not discuss standardization based on specific applications. In 2001, however, deliberations began on ERI (Electronic Registration Identification) standards as an AVI/AEI applied system designed for environment protection in the wake of proposal from CEN. ISO designated this as an official discussion item. Completed in 2004 were TS voting for pending ISO number 17261, CD voting on newly-discussed ISO number 24535, and WD and CD comment collection of ISO number 24534.

List of WG 4 work items (as of February 2005)

	Standardization themes	ISO numbers	Contents
1	Reference architecture and terminology for automatic vehicle identification/automatic equipment identification	DIS14814	Standardize architecture of AVI/AEI system
2	System specifications for automatic vehicle identification/automatic equipment identification	TS14815	Standardize classification of AVI/AEI system requirements
3	Numbering and Data structure for automatic vehicle identification/automatic equipment identification	TS14816	Standardize data compatibility of AVI/AEI system
4	Reference architecture and terminology for intermodal goods transport	TS17261	Standardize architecture of intermodal AVI/AEI system
5	Numbering and Data structure for intermodal goods transport	TS17262	Standardize data structure of intermodal AVI/AEI system
6	System parameters for intermodal goods transport	TS17263	Standardize classification of intermodal AVI/AEI system
7	Interfaces for intermodal goods transport	WD17264	Standardize interface specifications of intermodal AVI/AEI system
8	Electronic registration identification	WD/CD24534	Standardize specifications for the system where roadside equipment reads vehicle data electronically registered in the on-board equipment
9	Basic electronic registration identification(Basic ERI)	CD24535	Standardize specification for more simpler system

Scope of WG 4

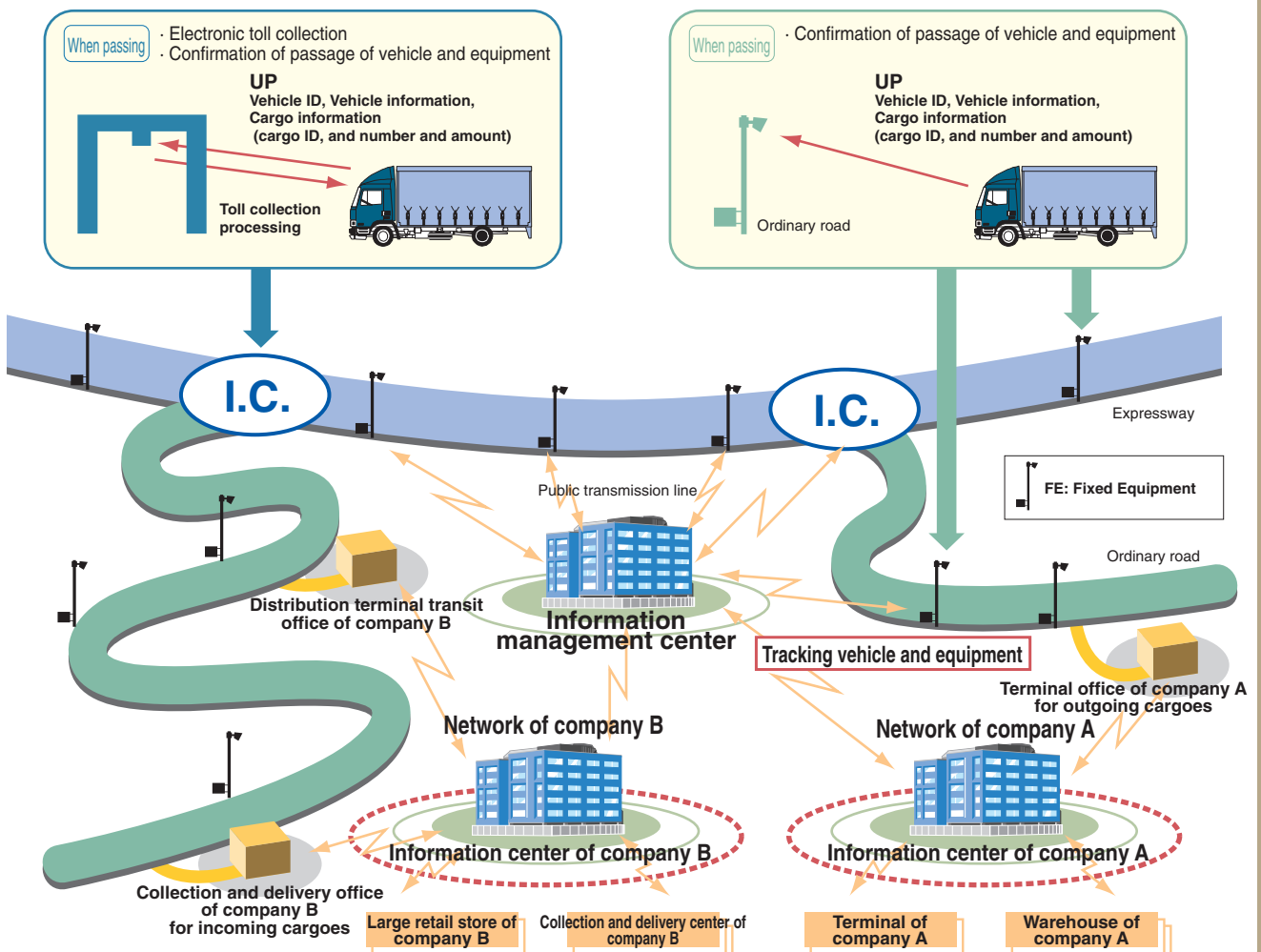

## System requirements for AVI/AEI system (TS 14815)

Various applications are considered for automatic vehicle and equipment identification—from a system only for slow-running vehicles to one for vehicles on expressways. Under this standard, classes are set up for major parameters (properties necessary to ensure compatibility) of AVI/AEI systems. For example, running speed of vehicles is defined according to seven classes (Table 1). Reading distance between the Tags on the vehicle and interrogator placed on the ground is defined in six classes (Table 2).

For example, when ordering a system, a user determines F4 of ISO/TS 14815 regarding running speed. As for interoperability of two systems, if one system designates F3 for running speed and C4 for reading distance, and the other F4 and C3, conditions for coexistence can be clearly defined.

Table 1: Vehicle/Equipment passing speed

CLASS	Maximum passing speed	
	km/h	m/s
F1	240	66
F2	160	44
F3	120	33
F4	72	20
F5	18	5
F6	9	2.5
F7	3.6	1

Table 2: Distance between vehicle/equipment and roadside devices

CLASS	Maximum reading distance
C1	20m
C2	10m
C3	6m
C4	3m
C5	1m
C6	0.5m

## Electronic Registration Identification (ERI)

Under ERI, roadside equipment communicates with on-board equipment for electronic vehicle identification. Two kinds of the standards are being planned—ERI for complex operation and for relatively simple identification. Originally, CEN made a proposal to ISO/TC/204/WG4 for technical measures to Directive 2000/53/EC of the European Commission and to “end of life” (a management program from manufacturing to disposal of vehicles for environment protection) of September 2000. In June 2003, the proposal was approved as an official work item at a plenary session of ISO/TC 204.

Scopes of ERI systems are (1) to give a unique identification number to each vehicle, (2) to make it possible to choose performance of on-board equipment through ERI application systems, and (3) to guarantee minimum compatibility between on-board and roadside equipment. Discussions on standards have been divided into Basic ERI using simple RF tags and Full ERI with application layer including data codes and others. In January 2005, CD voting was carried out on Basic ERI. As for Full ERI, discussions have been almost completed on five parts, including a proposal from Japan. In establishing this standard, ERTICO began to conduct questionnaires on operation of ERI systems in February 2003 under the request from the EC. The questionnaires were carried out until July 2004 in order to set the directions of ERI operation within Europe and reflect the results in international standards. Areas for possible applications of ERI systems are: (1) anti-theft vehicles, (2) access control, (3) road pricing, (4) vehicle registration, (5) vehicle tax management, (6) traffic flow control, (7) traffic rules and their observance, (8) environment protection from manufacturing to disposal of vehicles, and (9) hazardous material management.

In Japan, possible application areas of ERI are expected to be many, and involve numerous organizations. In August 2003, the “ERI business team” was founded with the Japan Automobile Research Institute as a secretariat. The team reports to domestic organizations possibly related to ERI systems on the contents of ERI deliberations in Europe, and submit proposals and comments on the ongoing development and prospects of ERI-related systems in Japan to the WG 4 Japanese committee.

## Liaison activities of TC204/WG4

TC204/WG4 has liaison relationship with ISO/IEC JTC1 SC31/WG4 (Standardization for automatic identification and data acquisition technology) both internationally and domestically. TC204/WG4 is deliberating on specifications designed to maintain interoperability between AVI/AEI systems, and on system architecture, data structure and standards for international registration for data exchange regarding ERI systems as an application area of AVI. In the meantime, SC31/WG4 is discussing RF tags and standards for compatibility between RF tags and on-board equipment. In other words, the areas handled by TC 204 include an application using RF tags or on-board equipment corresponding to RF tags, which are defined by SC31/WG4, and TC204/WG4 is leading applications of AVI/AEI systems.

# WG 5: Electronic Fee Collection

WG 5 is working on standardizing Electronic Fee Collection (EFC), TC 204 term including ETC and other fee collections, defining work items regarding charging and clearing of toll for roads, and fee for parking lots and ferries. Emphasis has been placed mainly on Electronic Toll Collection (ETC). Communication between vehicles and roadside equipment is implemented through DSRC (Dedicated Short Range Communication) or CN/GNSS (Cellular Network/Global Navigation Satellite System) using GPS and cellular networks. In April 2004, the European Commission issued the “Directive on the interoperability of Electronic Tolling Systems in the Community”. The directive recommends the adoption of the CN/GNSS system as an Electronic Tolling System in Europe while it does not exclude the conventional DSRC system for coexistence.

List of WG 5 work items (as of February 2005)

	Standardization themes	ISO numbers	Contents
1	Interface specifications for clearing between operators	TS14904	To prescribe interface for clearing between EFC operators with a pentagonal EFC concept model
2	EFC application interface definition for DSRC	ISO14906	To prescribe data structure and commands, etc. to make sure interoperability of EFC applications using DSRC
3	EFC Test procedures for user and fixed equipment - Part 1	TS14907-1	To prescribe procedures and conditions for tests of EFC-related equipment
4	EFC Test procedures for user and fixed equipment - Part 2	TS14907-2	To prescribe conformance tests for On-Board equipment, conforming to EFC application interface definition (ISO 14906).
5	EFC System architecture	TS17573	To define reference architecture for the entire EFC system and prescribe framework of various EFC-related conditions
6	Framework for EFC security services	TS17574	To refer to ISO/IEC 15408 (IT security evaluation standard) and give guidelines for EFC security establishment
7	EFC application interface definition for CN/GNSS based EFC	DTS17575	To prescribe data structure and commands, etc. to insure interoperability of EFC applications using Cellular Networks and Global Navigation Satellite System (CN/GNSS)

## Entire structure of EFC and scope of WG 5

EFC-related entities include Card Issuer, Service Provider, Clearing Operator and Collection Agent with their relationship shown in the figure below. WG 5 is working on standardization of the EFC application interface (data elements and command definition, etc.) both for DSRC and CN/GNSS, which are means of communication between Service Provider and Users, and of the test procedures and data security. WG 15 and ITU-R are working on standardization of DSRC.

Entities involved in EFC and Scope of WG 5

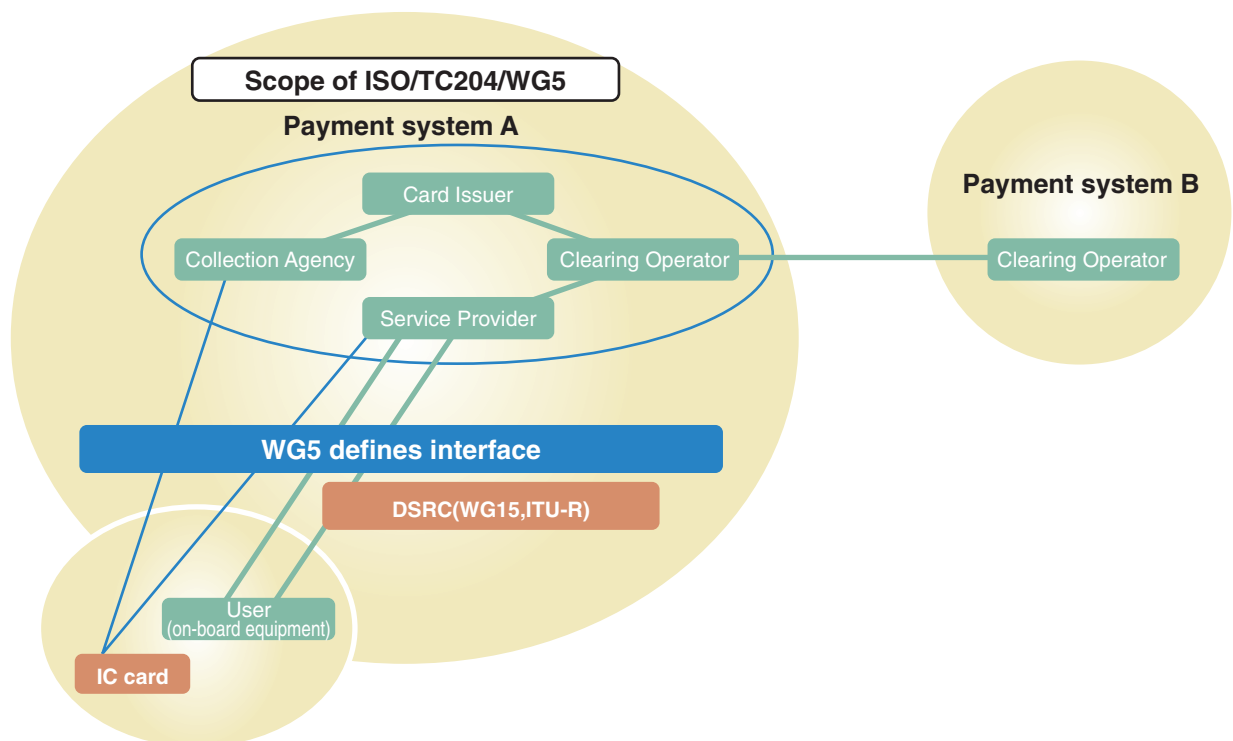

Shown below is the ETC system configuration in Japan and corresponding ISO standards and ITU recommendations.

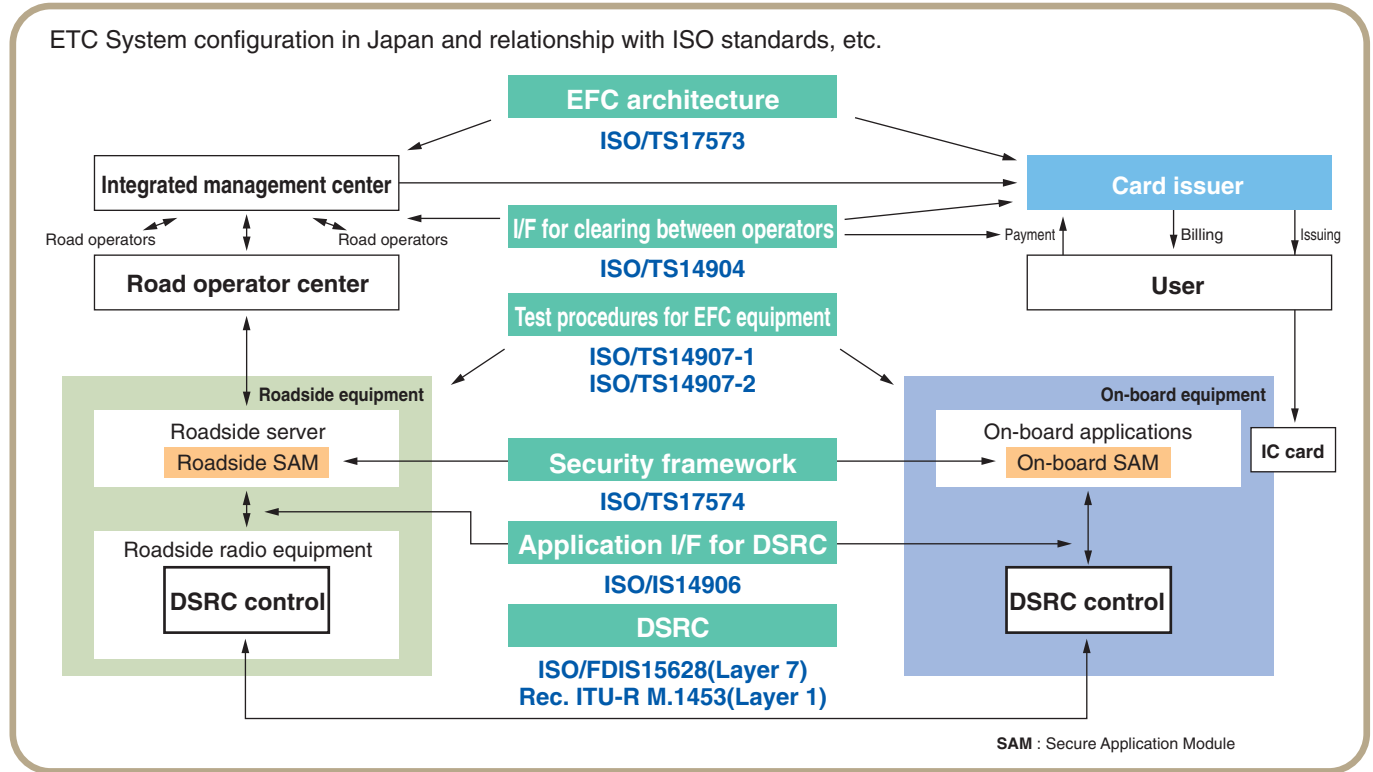

## Application interface definition for CN/GNSS (ISO/DTS 17575)

The CN/GNSS based EFC was approved as a work item in 1997, and the initial draft preparation was completed in December 2004. Toll collection system for Heavy Goods Vehicle (HGV) in Germany, which went into operation on January 1, 2005, adopts this system. A built-in GNSS (GPS) receiver in on-board equipment monitors the coordinates of the current location continuously. The location is mapped through the geographical information stored in the on-board equipment and the fee to be collected is calculated using the location information and the toll information downloaded through Cellular Network. Generally the fee is calculated within on-board equipment, and is recorded either on an IC card or at an information center through Cellular Network. For the fee calculation, a zone toll method for each passage through virtual toll area or distance-based toll method is used. The following figure is an example of on-board equipment integrating DSRC as an option to enable the EFC interoperability throughout European countries.

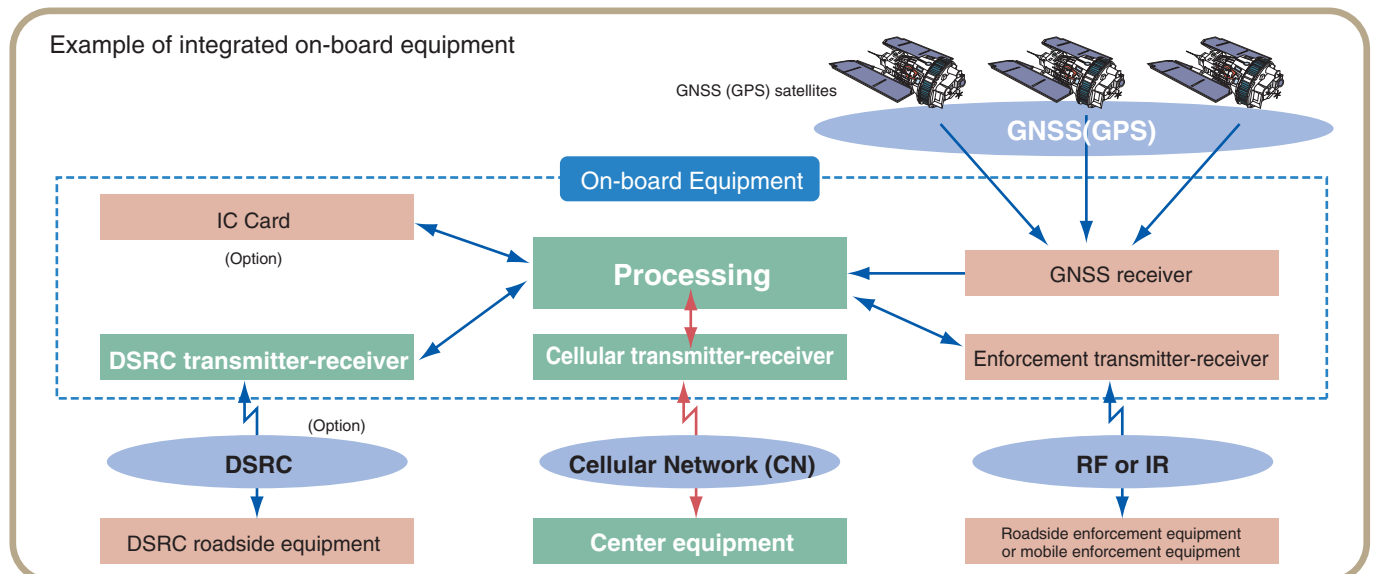

# WG 7: General Fleet Management and Commercial/Freight Operations

Initially, WG 6 (General Fleet Management) and WG 7 (Commercial/Freight) carried out work on standardization separately. In November 1999, WG 6 and WG 7 were integrated at a conference in Montreal into a new WG 7. At this conference, a new work item on transportation of hazardous materials was also approved to launch work on its standardization. The new item was proposed by Canada at a preceding meeting in Amsterdam in June 1999.

In Japan, management of hazardous material transportation is designated as user service “management of special (overload, overlength, overheight) heavy vehicles that are permitted by regulation” related to development area “increased efficiency of road management” in the ITS system architecture. In the wake of the above-mentioned Canadian proposal, a business team consisting mainly of WG 7 members was set up under the then TC 204 domestic committee to study compatibility with the emergency response sheets named "yellow card" likely to be made obligatory on the basis of the “distribution safety guidelines.”

WD on preparation of hazardous materials/dangerous goods transportation management was submitted at a Naples conference in November 2000, and another WD (first version) at a Hawaii meeting in April 2001 to launch discussions. In May 2002, a proposal to revise standard messages comprehensively with consideration for IEEE's preliminary proposal was submitted at a London conference, and the CD phase was approved at a Chicago meeting in October 2002. It was resolved at a Vienna conference in October 2003 to proceed to DIS voting after addressing comments from each country. It is in the DIS voting phase (deadline for March 2005) (WG 7.1).

Meanwhile, at a London conference in May 2002, the United States proposed that transportation of general cargoes be managed under the whole process of overland cargo transportation in order to improve security and efficiency. This standardization plan was approved as a new PWI. As it is likely to concern an entire distribution system, have great influence on the related industry and involve many organizations in discussions on standardization, a domestic committee separate from the WG 7 Domestic working group has been set up for deliberations.

List of WG 7 work items (as of February 2005)

	Standardization themes	ISO numbers	Contents
1	Data Dictionary and Message Sets for Electronic Identification and Monitoring of Hazardous Materials/Dangerous Goods Transportation	DIS17687 (WG7.1)	Definition of data dictionary and message sets necessary for automatic identification and monitoring, which makes it possible to exchange information among vehicles, management centers, related organizations, carriers, and senders and receivers of cargoes, regarding hazardous material transport
2	Data dictionary and message set to facilitate the movement of freight and its intermodal transfer - Road transport information exchanges	CD24533 (WG7.2)	Definition of data dictionary and message set necessary for monitoring, which makes it possible to manage ordinary cargoes in the whole transportation process through tags attached to cargoes

## WG 7.1 Standardization of Data Dictionary and Message Sets for Electronic Identification and Monitoring of Hazardous Materials/Dangerous Goods Transportation

Subject to this standardization are data dictionary and message sets to support exchange of information on hazardous materials, and automatic identification and monitoring. This standard can possibly be applied to various forms of communication media, such as DSRC and cellular phones.

Cited below are effects of standardization.

1. Real-time information collection (identification of vehicles, information on hazardous materials)
2. Support to cooperation between operators and emergency responders (police, fire fighters, etc) when an accident occurs at a time of hazardous material transport
3. Monitoring of physical conditions (temperature and pressure, etc.) during hazardous material transport

In Europe and the United States, intermodal transport involving ships, railways and trucks is common in hazardous material transport. These standardization items are considered effective for one-stop services at borders.

Typical System Architecture D/G Transportation

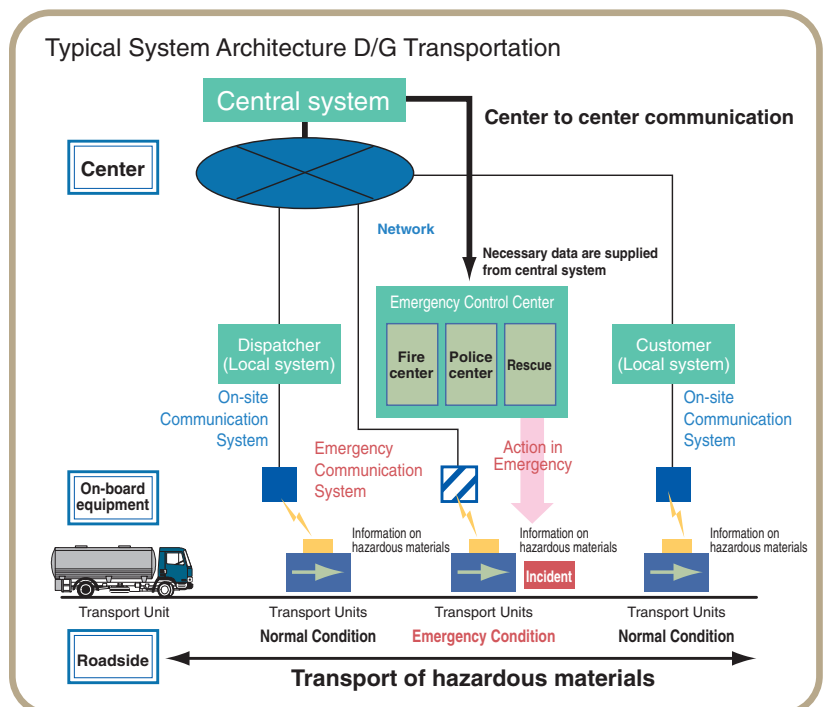



## WG 7.2 Standardization of Data dictionary and message set to facilitate the movement of freight and its intermodal transfer - Road transport information exchanges

Subject to this standardization are data dictionary and message sets to be exchanged between a shipper and several transport organizations in door-to-door transport. Specifically, it is standardization of data elements used for electronic data interchange (EDI) and messages (clusters of data elements) necessary in supply chain.

Door-to-door transport requires international integrated transport involving trucks, railways, ships and airplanes. A different EDI is used for each transport organization. It will take a great deal of time and effort to unify data standards different according to each country and organization, and to introduce rules for standard information exchange. For the time being, standardization work is limited to air cargoes and study is being made on Electronic Supply Chain Manifest (ESCM) to be exchanged among shippers, forwarders, truck carriers, airports and airlines, and on procedures for exchange of information. The study is also designed to realize visibility and traceability of door-to-door cargoes, while pursuing compatibility with existing rules for data exchange and information exchange systems.

Developed so far have been four messages—registration of cargo data, changes in carriers, renewal of cargo data and completion of transport—and 62 data elements. Information exchanged among a series of entities is captured at a road traffic information exchange point for real-time knowledge of cargo location. This standard can be applied to security of truck transport and cargo transport among several transport organizations.

Real-time knowledge of cargo location in door-to-door transport is expected to improve supply chain management of shippers and third-party logistics dramatically and apply to business, which means high economic values.

This standardization work has been promoted in cooperation with UN/CEFACT (UN/ Center for Trade Facilitation and Electronic Business), WCO (World Customs Organization), IMO (International Maritime Organization), other technical committees of ISO (containers and packing), IATA (International Air Transport Association), and SMDC (User Group for Shipping Lines and Container Terminals).

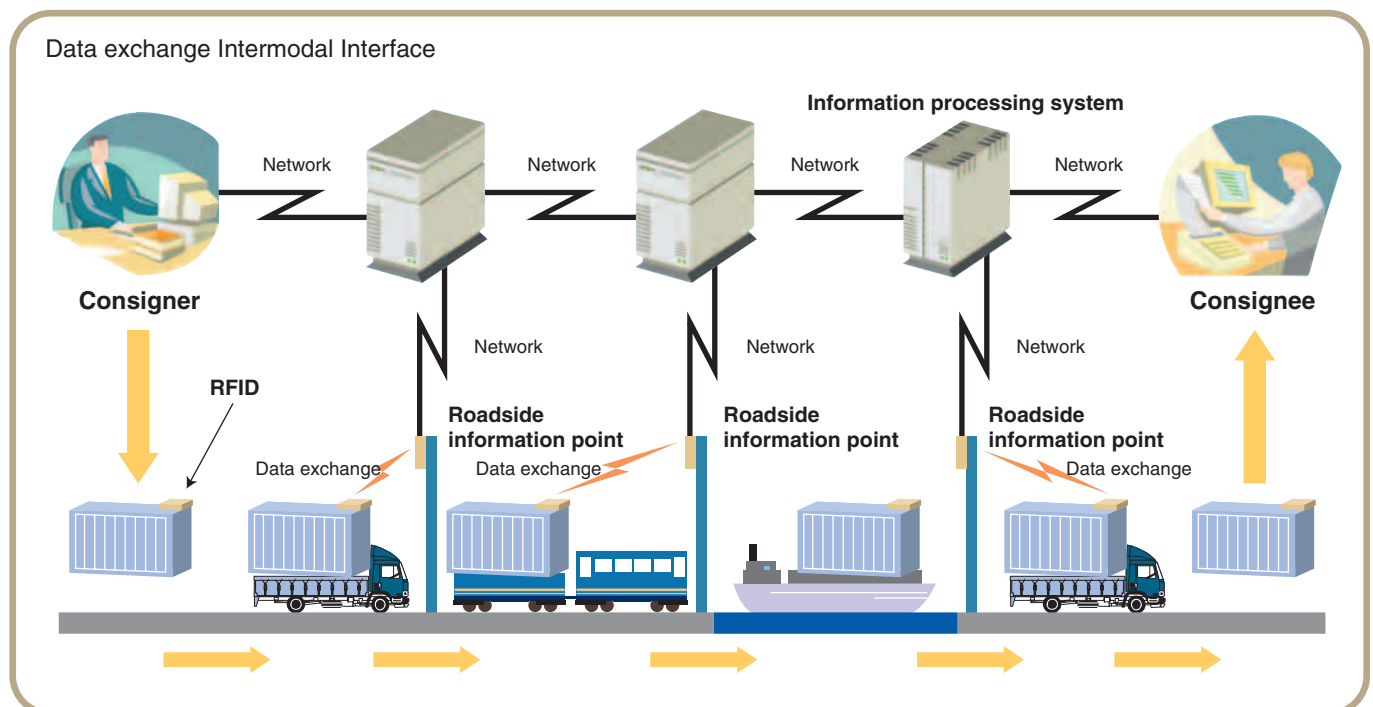
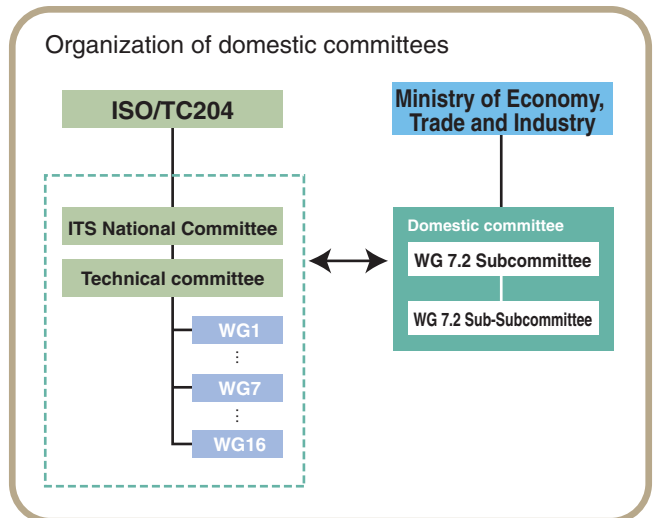

## WG 8 Public Transport and Emergency

WG 8 is working on standardization of information related to public transport. Public transport includes buses, trains, trams and emergency vehicles

Among specific standardization items are Public Transport Communications Interface Protocol (TCIP) whose draft is being prepared mainly by the United States and Data Dictionary and Message Sets for Preemption and Prioritization Signal Systems for Emergency and Public Transport Vehicles (PRESTO) proposed by Japan. In 2003, PWI was adopted on “Public Transport Interoperable Fare Management System” and “ITS Emergency Services Communications Interfaces.” (However, “Emergency Services” were canceled later.)

List of WG 8 work items (as of February 2005)

	Standardization themes	ISO numbers	Contents
1	Public Transport Communications Interface Protocol (TCIP)	CD17686	Standardization of data dictionary and message sets for exchange of data related to public transport
2	Data Dictionary and Message Sets for Preemption and Prioritization Signal Systems for Emergency and Public Transport Vehicles (PRESTO)	CD22951	Standardization of data dictionary and message sets for traffic signal preemption and prioritization for emergency and public transport vehicles
3	Public Transport Interoperable Fare Management System	NP24014-1	System architecture for fee collection system using IC card tickets

### Importance of Public Transport

The reason why WG 8 has adopted public transport as an important standardization theme is that excessive dependence on automobiles for passenger and cargo transport can do serious harm to our society and life, and damage sustainability. To reduce the dependence on automobiles, it is necessary to increase the density of cities and make cities compact, and then to change transport modes from automobiles to foot, bicycles and public transport. However, automobiles provide door-to-door transport and comfort, and direct cost borne by a driver is considered generally lower than that of public transport.

It is effective to enhance the attractiveness of public transport in order to promote a shift to public transport. Toward that end, information has an extremely important role to play. Progress in information technology has made it possible for people to get information on routes, transfer, operation, travel time and fees of public transport before and during traveling, and to choose an optimum route. In order to enhance attractiveness of public transport dramatically, it is of course necessary not only to apply advanced information technology but to implement measures systematically and comprehensively, such as removal of physical barriers at a time of transfer, inexpensive and easy-to-understand fares as well as simple payment, and land use with priority given to convenience for users of public transport.

### Public Transport Communications Interface Protocol: TCIP (CD 17686)

TCIP is designated as one area of the National Transportation Communications for ITS Protocol (NTCIP), a comprehensive communications specifications used in the entire ITS system of the United States. It is designed for more efficient information exchange in operation management of public transport vehicles, information services for passengers, and fee collection. As standardization themes, WG 8 has been studying definition of terms common to public transport, operation plans, on-board systems, operation management centers, passenger information, incident management and spatial representation. However, the United States has decided to make a thorough revision of TCIP, and a new version of TCIP is being prepared. Considering this revision, standardization themes are likely to be changed. Therefore, Japan has decided to wait for the completion of the new version scheduled for autumn 2005.

One of the problems over TCIP is harmonization with Trans Model now under study at CEN/TC 278. The United States is playing a leading role in harmonization with Trans Model. It is also necessary to make adjustment with TPEG examined by WG 10 and location referencing for which WG 3 is promoting standardization.

#### Examples of experimental introduction of TCIP standards scheduled for the next few years in the U.S.

Examples of future experimental introduction of TCIP standards in the United States include supply of information for passengers (electric display at bus stops, in-vehicle display) and operation management (accident and breakdown management, local passenger information).

#### Trans Model

This is a data description methodology used for information systems related to public transport in Europe. It is a conceptual model independent of implementation design and logical/physical levels, and is commonly used for different platforms to guarantee interoperability of software resources between information systems and establish highly secure and reliable systems. Data items handled include strategic planning, employee/operation management, passenger information, fee collection and operation statistics. Trans Model has been proposed by France mainly in consideration for needs of bus operators. It was registered as ENV 12896 (European preliminary standard) in 1997. It is now under study at CEN/TC278/WG3 (public transport) SG 4 toward establishment as a European standard.

## Data Dictionary and Message Sets for Preemption and Prioritization Signal Systems for Emergency and Public Vehicles: PRESTO (CD 22951)

PRESTO is designed to exchange data efficiently for traffic signal preemption and prioritization so that such public transport vehicles as emergency vehicles, buses and trams pass intersections preferentially over other vehicles. Data are in principle exchanged between vehicles and roadside equipment. Standardization scope includes data dictionary and message sets in mobile communication fields—the same as in TCIP.

Specifically, traffic signals are controlled (longer green lights and shorter red lights) on the basis of information on location of emergency vehicles, running speed, destination and the direction of travel at an intersection so that emergency vehicles can pass an intersection quickly. At the same time, passage of emergency vehicles is informed to other vehicles and pedestrians to prevent collision. Subject to standardization work item for the time being is signal control.

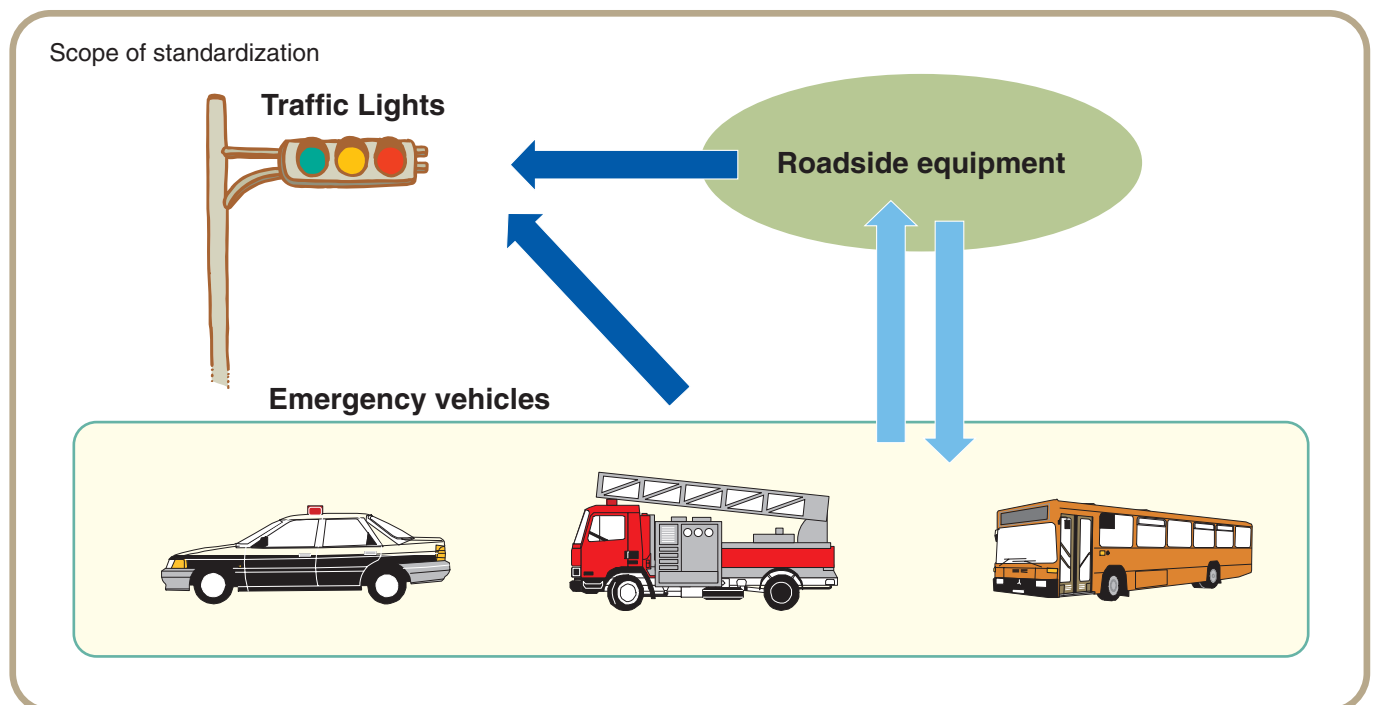

## Public Transport Interoperable Fare Management System (NP 24014-1)

The Interoperable Fare Management System (IFMS) is comprehensive architecture for the whole related systems with a view to efficient operation and management of fare collection through IC cards in railways, buses and other public transport. In Europe, CEN/TC278/WG3 is leading the standardization of the system. In view of the social significance of IFMS, WG 8 decided to standardize IFMS in cooperation with CEN, and PWI proposal was approved in October 2003. Procedures for NP voting were also approved in October 2004.

In Japan, IC cards called "suica" are used widely, while they are increasingly used in other Asian countries. It is necessary to reduce the gap between the standardization of IFMS and trends in various countries.

## Other work items

Australia proposed to WG 8 standardization for numbering of bus stops and railway stations. WG 8 worked on the item but suspended it later. The work was then resumed due to a strong request from South Korea, which insisted that such a numbering system be introduced. PWI proposal will be made in 2005.

# WG 9: Integrated Transport Information, Management and Control

Subject to study by WG 9 is standardization for traffic management (transport information and control, etc.). Specifically, it is working on systematization of information and standardization of communication systems in order to exchange data efficiently between traffic management centers, centers and roadside modules, and roadside modules, and to provide information for outside organizations.

List of WG 9 work items (as of February 2005)

	Standardization themes	ISO numbers	Contents
1	Data interfaces between Centers for Transport Information and Control Systems – Message Definition Requirement	FDIS14827-1	Definition of message forms between centers for Transport Information and Control Systems
2	Data interfaces between Centers for Transport Information and Control Systems – DATEX-ANS Application	FDIS14827-2	Definition of communication protocol using DATEX-ANS between Centers for Transport Information and Control Systems
3	Data Exchange involving Roadside Modules: Part1 Framework and overview Application profile	NP15784-1	Principle of application profiles and framework for documentation regarding communication between TICS centers and roadside modules
4	Data Exchange involving Roadside Modules: Part2 Application profile-TMP	NP15784-2	Application framework based on TMP of communication between TICS centers and roadside modules
5	Data Exchange involving Roadside Modules: Part3 Application profile-DATEX	NP15784-3	Application framework based on DATEX-ASN (ISO 14827) of TICS centers and roadside modules
6	TICS-Integrated Transport Information, Management and control-Data dictionary - Data dictionary	PWI	Data dictionaries in TICS traffic management area
7	TICS-Integrated Transport information, Management and control-Data dictionary – congestion monitor Use Case	PWI	Data model for congestion monitoring use case of TICS transport management area
8	Quality of input Data for ITS	NP21707	Definition of quality of input data for ITS

## Activities

Scope(inter-centers, centers and roadside modules, inter-roadside modules) of standardization WG 9 is working on are shown in the figure. Centers refer to transport management centers. Roadside modules refer to signal control devices, information boards and sensors installed on the roadside. One of the advantages for promoting standardization of information and communication between centers, and centers and roadside modules is inter-connectivity. It will be easy for module procurers to purchase modules from multi-venders, while it will be possible for module suppliers to reduce development burdens and risks.

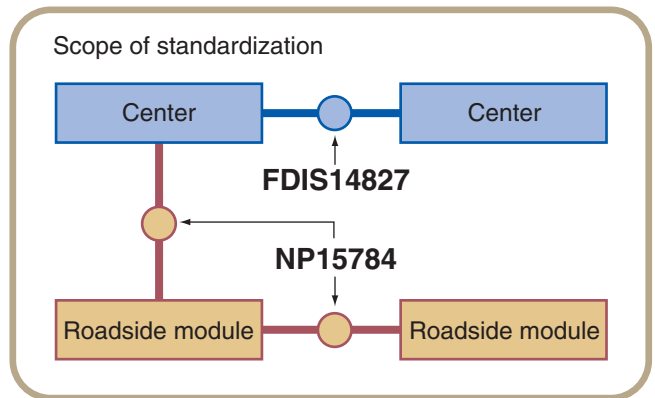

## Standardization for communication between centers (FDIS 14827)

Inter-center communication means communication between transport management centers. Under this communication, information a transport management center collects is exchanged with a neighboring center to make possible implementation of extensive transport management. WG 9 has stipulated definition forms of messages and protocol for exchange of messages when information is exchanged between centers.

Definition forms of messages refer to what should be described when a message is defined. For example, the name of a message, a text and a form (data type).

Designated as a procedure for information exchange is a protocol called DATEX-ASN. DATEX-ASN is a protocol developed in the United States for inter-center communication in the ITS domain. This protocol is based on DATEX-Net (a standard protocol for inter-center communication in Europe), which is considered to satisfy various requirements for inter-center communication in the ITS domain and adopts ASN.1 as a description language, which is the standard notation method in TC204. Therefore, DATEX-ASN is compatible with international standards.

This proposal was approved through DIS voting, and procedures are being taken to proceed to the next step (as of November 2004). From now on, messages to be exchanged will be defined in work items of data registry.

Standardization of inter-center communication



## Standardization of communication between centers and roadside modules (NP 15784-1-3)

Communication between centers and roadside modules means exchange of information between central modules of a transport management center and modules installed on the roadside and between these roadside modules. WG 9 plans to prescribe this communication in the form of application profile. This application profile designates a set of base standards regarding three upper layers of OSI to meet the requirements of communication between a center and roadside modules and prescribes how to use base standards. Designated under the initial version will be Transportation Management Protocols (TMP), a part of the National Transportation Communication for ITS Protocol (NTCIP). It is a communication standard for the ITS range in the United States, and DATEX-ASN of FDIS14827, an international standard for communication between transport management centers. How to use them will also be stipulated.

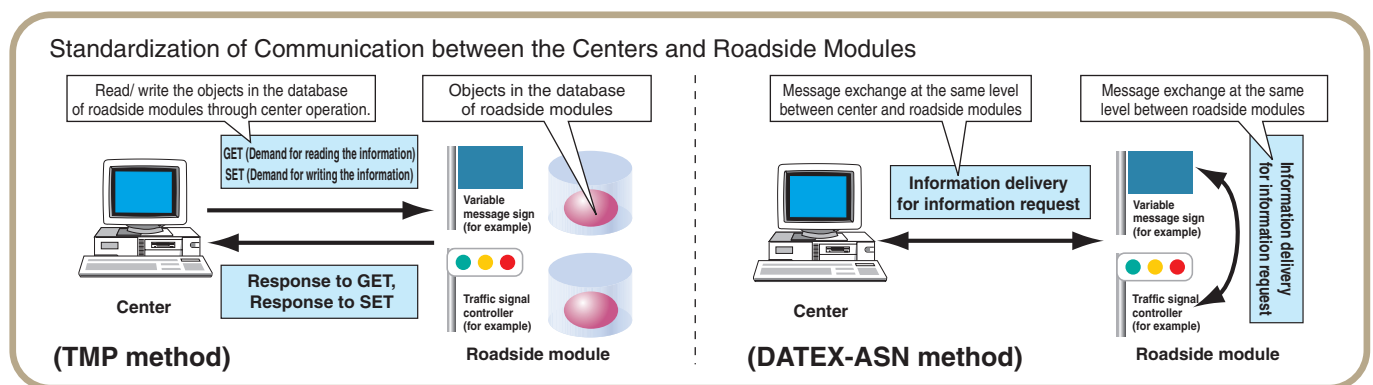

## Data dictionary of road transport management (PWI)

A data dictionary compiles definitions of various data to be used in a specific area in a dictionary manner. With this dictionary, experts trying to develop a new standard in a field concerned and persons trying to establish applications in a field concerned based on a standard can obtain standard and unambiguous understanding on the meanings and forms of data. The preparation of a data dictionary begins with clarification of applications and mutual relations of data used within such applications (data modeling).

Japan has prepared a data model/data dictionary for application of providing information for road transport information boards and thus, played a major role in this area. With the application of providing congestion data selected, study has been launched on the need and possibility of preparation of a data dictionary as an international standards.

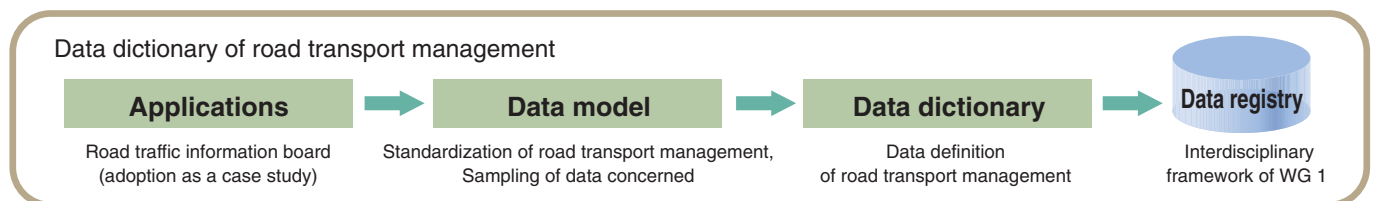

## Quality of input data for ITS (NP 21707)

This standard specifies the format for defining the quality of quantitative data being exchanged between systems (including users) in a transport information application. In recent years, many users wish to allocate the obtained data to the one that they are providing. If they don't specify the quality of the data, they can't do so. The standard is intended to define the standard for 10 items, including accuracy, reliability and timeliness, regarding transport information. UK is playing a leading role in this area, and voting is underway as of November 2004.

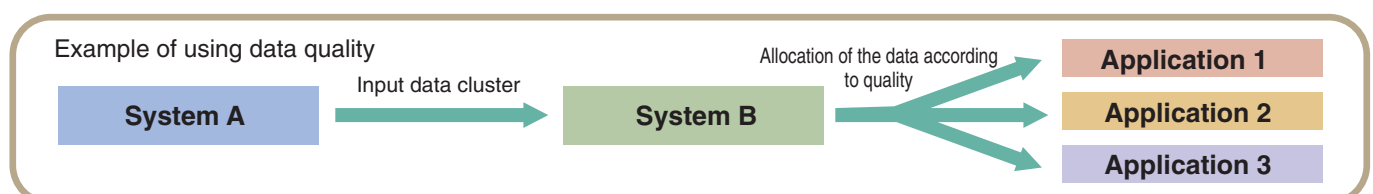

# WG 10: Traveller Information Systems

Traveler information systems, subject to standardization by WG 10, constitute a core part of ITS. This working group has work items designed to study data dictionaries and message sets to provide information for drivers through various media, such as FM broadcasting, DSRC, cellular phones and digital broadcasting. Recently, brisk activities have been witnessed in integration of user services led by North America and Japan, and XML standardization of TPEG(Transport Protocol Export Group)led by Japan.

List of WG 10 work items (as of February 2005)

Standardization themes	ISO numbers	Contents
1 TTI messages via transport message codes	ISO14819-1	Standardization of the RDS-TMC system adopted in Europe
	SO14819-2	Code definition of TTI messages
	FDIS14819-3	Location referencing method
	DIS14819-6	Regulation of conditional access
2 TTI messages via cellular phone networks	TR14821	Standardization of various information supply services, such as emergency notification and breakdown support using cellular phone networks, route guidance, supply of transport information, operator services, transport information collection
3 Medium-range pre-information	CD14822-1	Standardization of transport information supply through DSRC networks (downlink)
	CD14822-2	Standardization of gather of information, such as local traffic condition and emergency measures (uplink)
4 Infrastructure information supply system	CD14823	Standardization of pictogram data dictionary codes
5 Interaction of user services for TTI message list	WD15074	Standardization of common message subsets to be used for services handled by WG 10
6 TTI messages using broadcasting-type digital media	TS18234-1	Standardization of Transport Protocol Expert Group (TPEG) through digital broadcasting
	TS18234-2	Explanation of terms and frame structure
	TS18234-3	Services and network information
	TS18234-4	Road transport message applications
	TS18234-5	Public transport information
	TS18234-6	Location referencing
	WD24530,PWI	XML-regulated next-generation TPEG

Note: TTI (traffic and traveler information), RDS-TMC (radio data system-traffic message channel)

## Medium-Range Pre-Information (CD 14822)

This work item is designed to study standardization of medium-range pre-information (MRPI) using DSRC. Standardization plans have been submitted on the basis of demonstration tests in Europe for downlink of information on rain and accidents from DSRC installed on expressways and for uplink of wiper operation information to DSRC. The Japanese working group suggested that a draft include the statement to the effect that Application Identification (AID) standardized at WG 15 is international standardization of the service equivalent to 8 (use of CEN standard DSCR), which was accepted.

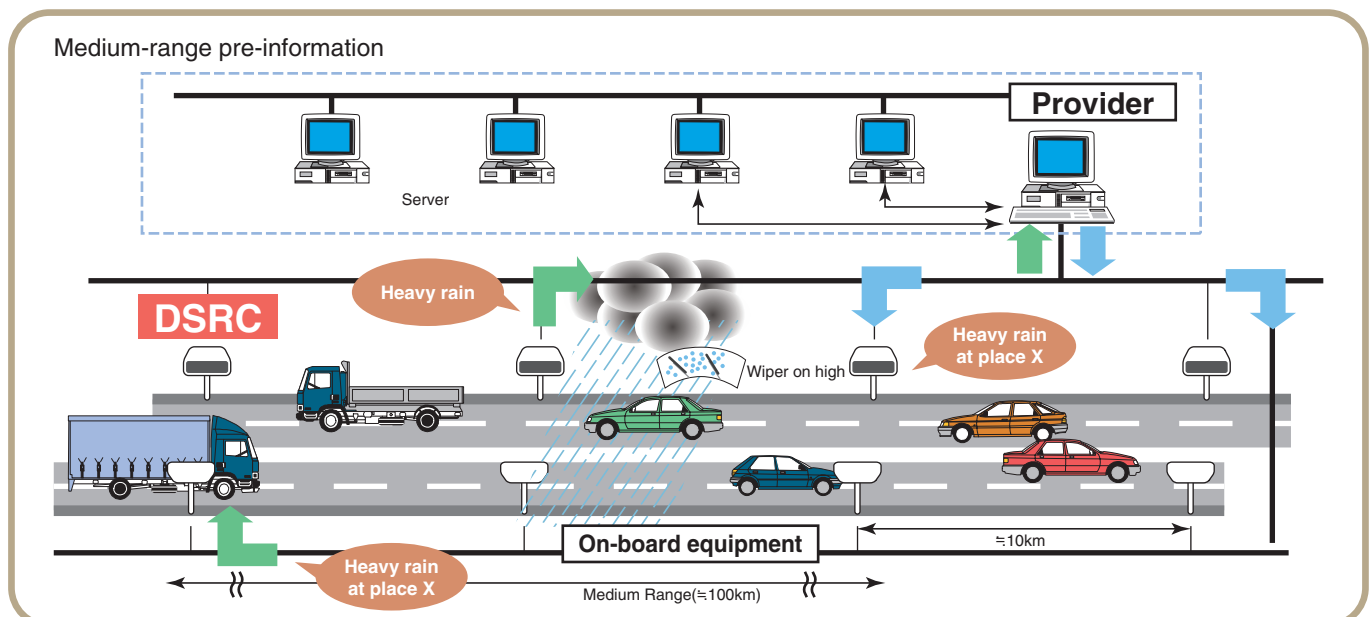

## Infrastructure Information Supply System (CD 14823)

This work item is the standardization of a graphic data dictionary (GDD) of pictogram including signs for road transport guidance and designs. This is intended to display variable information boards and pictogram equivalent to on-board equipment with GDD codes transmitted by providers. As pictogram varies from country to country, only codes signified by pictogram, not pictogram or designs, are subject to standardization. Japan is playing a leading role in this area and work is going smoothly for standardization with support from Europe. Scheduled soon is ISO TS voting circulation.

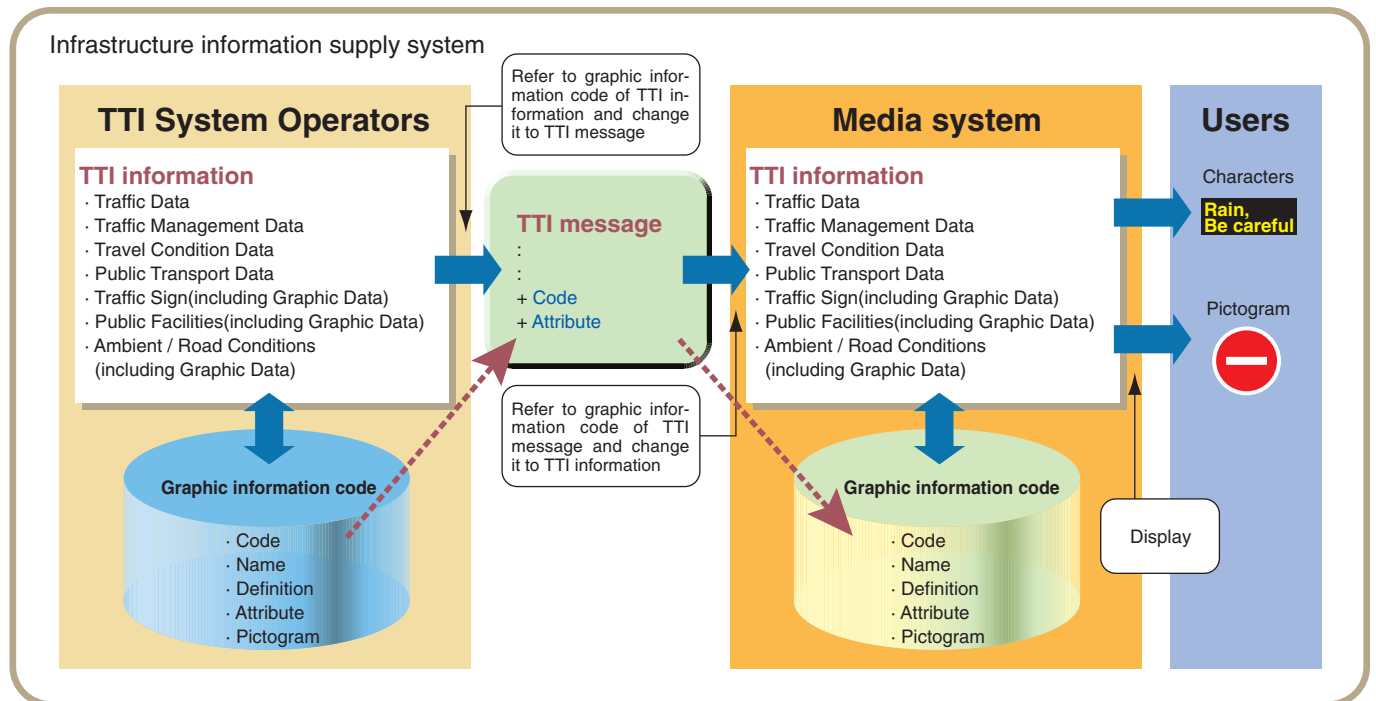

## TTI Messages Using Broadcasting-Type Digital Media (TS 18234, PWI/WD 24530)

TPEG is a standardization plan regarding a transport information supply system using high-speed digital data broadcasting, which is proposed by CEN TC 278 WG4 SWG 4.7 (hereinafter referred to as CEN). The next-generation TPEG business team submitted two standardization plans-for parking lot information, and for information on congestion and traveling time as TPEG applications-from ISO TC 204 WG 10. In September 2002, PWI was approved at a general meeting of ISO TC 204. Almost all the preparation of WD on parking lot information has been completed, waiting for comment circulation. Discussions have been launched on information on congestion and traveling time, and Japan is promoting study mainly on link methods.

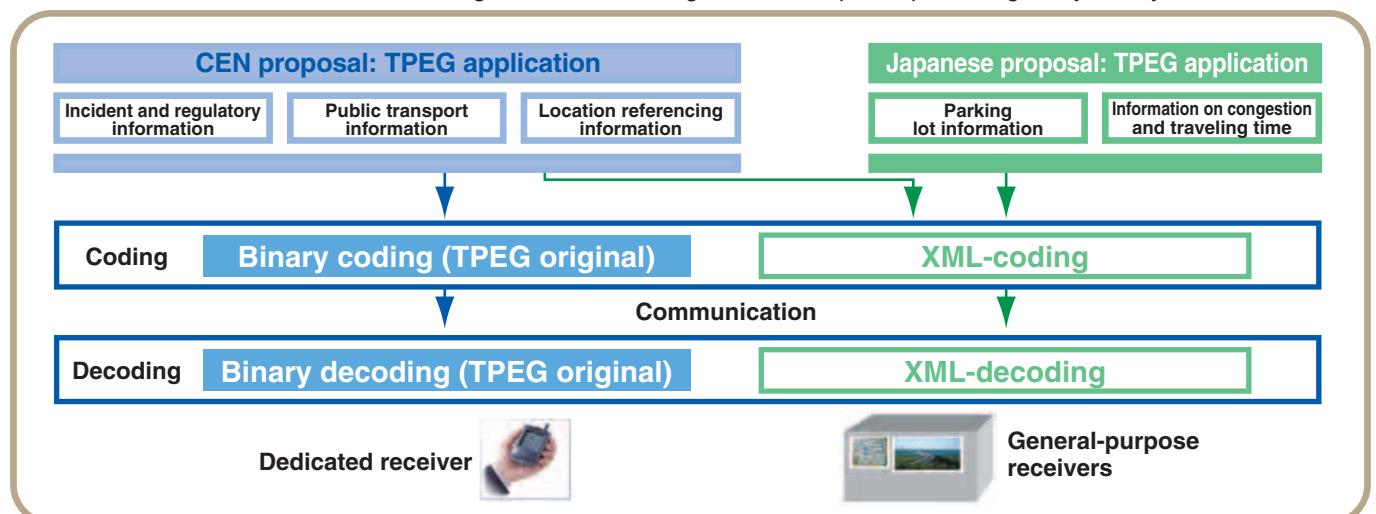

# WG 11: Route Guidance and Navigation Systems

WG 11 is in charge of the standardization of route guidance and navigation systems. It has thus far worked on “navigation message set,” “centrally-determined route guidance” and “message set translator” under the standardization item related to message sets by navigation systems, and “on-board system architecture” under the standardization item linked to architecture of on-board systems.

List of WG 11 work items (as of February 2005)

	Standardization themes	ISO numbers	Contents
1	Navigation message set	ISO15075	Prescription of necessary items for message sets to be handled by on-board navigation systems
2	Centrally-determined route guidance	TR17384	Prescription of necessary items for interactive CDRG messages sets exchanged between a center and vehicles
3	On-board system architecture	DPAS16914	Prescription of reference layer model capable of describing hierarchically the structure of on-board information systems
4	Message set translator	PAS17684	Simple notation of table forms regarding message sets and supply of conversion tools to ASN.1

## On-Board System Architecture Reference Layer Model (DPAS 19614)

Underway is the standardization of a reference layer model in order to promote standardization work related to on-board systems.

The reference layer model is a standardized hierarchical model designed to express various on-board systems, such as navigation systems and next-generation on-board systems. It will make it possible to express models incorporating various restrictions on on-board systems—coordination between communication media for access to information sources, coordination between data obtained from information sources and structure of information accumulation to ensure responsiveness to users. Systems proposed individually are expressed after being applied to the reference layer model, highlighting differences in the contents of standardization for each system. This will result in smooth progress in standardization.

This activity is in the publication stage as ISO/PAS.

Reference layer model

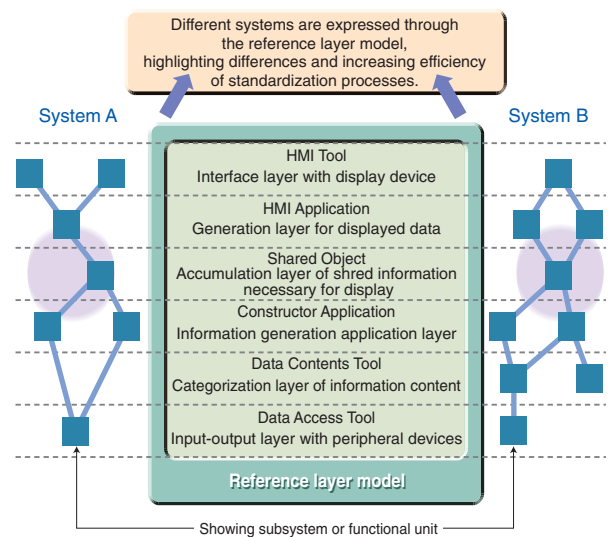

Example of structure regarding on-board information system communication media Reference layer model

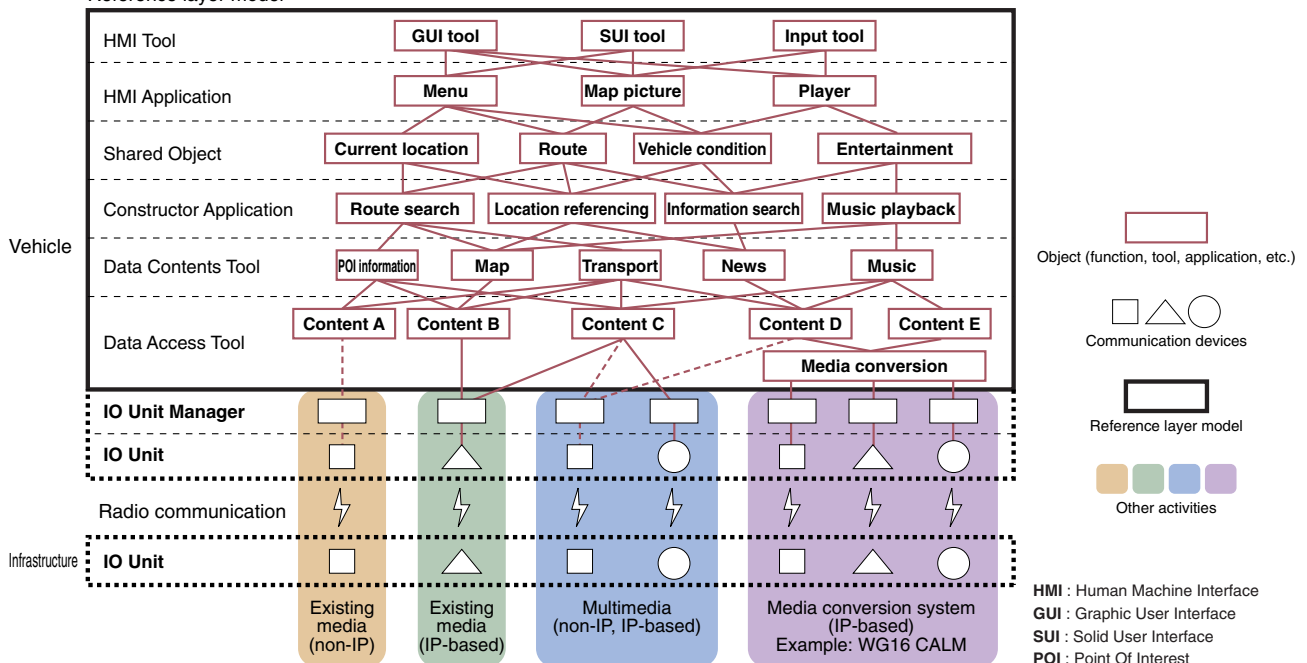



# WG 14: Vehicle/Roadway Warning and Control Systems

## Activities of WG 14

“Driver support systems control” means control technology on vehicles directly linked to drivers, and forms a central part of ITS. The purpose of this area is to reduce load on drivers, improve convenience, arouse awareness of dangers, and avoid accidents and decrease damage, using advanced technology. Already put on the market have been adaptive cruise control systems (ACC) and forward vehicle collision warning systems (FVCWS).

Subject to standardization are contents regarding “vehicle/roadway warning and control systems” with a view to international uniformity of systems. Specifically, the work covers wide-ranging areas from vehicle control, sensing of and communication with external information and interface with drivers.

Numerous countries take part in WG 14 chaired by Japan. With its work going smoothly, WG 14 is one of the most active groups in ISO/TC 204.

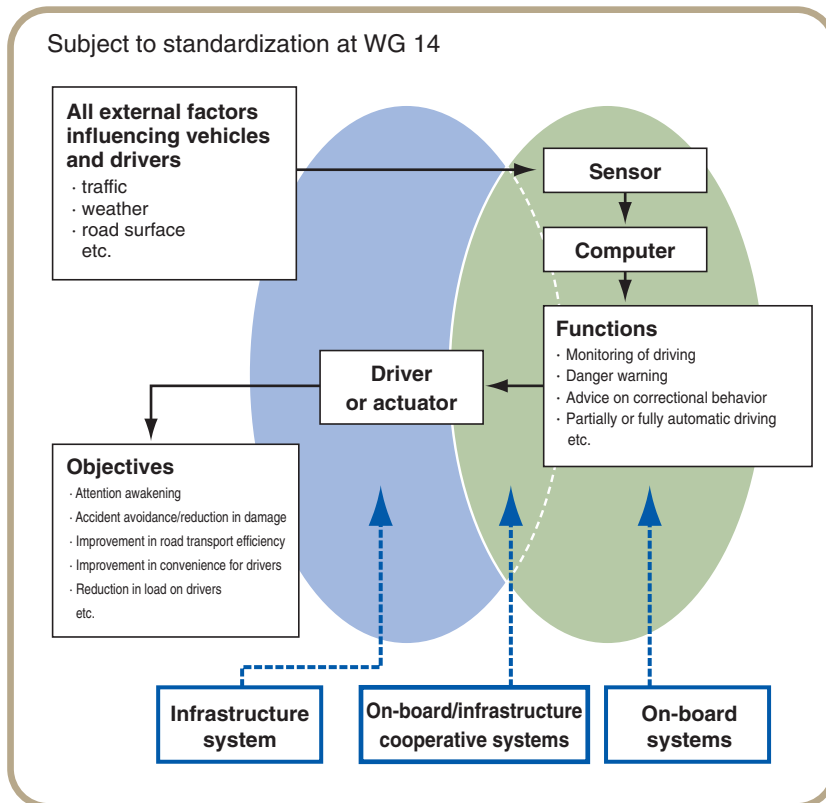

List of WG 14 work items (as of February 2005)

	Standardization themes	ISO numbers	Contents
1	Adaptive Cruise Control Systems (ACC)	ISO15622	System to keep a certain distance with a vehicle running in front, To prescribe classification according to existence of a clutch and an automatic brake, control strategy and characteristics of a driver's intervention
2	Forward Vehicle Collision Warning System (FVCWS)	ISO15623	System to prompt a driver to put a brake and prevent a rear-end collision, To prescribe the range of detecting a vehicle running in front and detection performance, and evaluation methods
3	Roadside Traffic Impediment Warning System (TIWS)	TS15624	System to identify an obstacle on a bending in front through a roadside sensor and inform a driver using roadside message board
4	Maneuvering Aid for Low Speed Operation (MALSO)	ISO17386	System to provide information on obstacles found in a rear end and a corner of a vehicle at a time of back-up and a turnaround at a low speed, To prescribe classification based on detection areas, system operation conditions and test methods
5	Lane Departure Warning Systems (LDWS)	DIS17361	System to warn a driver of an actual or possible departure from a lane due to carelessness, To prescribe definition of lane departure, conditions for warnings and test methods
6	Lane Change Decision Aid Systems (LCDAS)	CD17387	System to provide information on a vehicle running in a blind spot or a vehicle approaching from behind when a driver tries to change a lane, To prescribe classification based on areas covered, conditions for warning and test methods
7	Low Speed Following Systems (LSF)	NP22178	System unrelated to ACC and designed to place emphasis on following control on a low-speed vehicle on a expressway at a time of congestion
8	Full-Speed Range Adaptive Cruise Control Systems (FSRA)	NP22179	System to expand to stop control on following functions of ACC, To prescribe the definition of a vehicle running in front, how to restart, and operation limits of a system
9	Forward Collision Avoidance Assistance Systems (FCAAS)	PWI	System to carry out an automatic emergency stop and reduce damage from collision when a vehicle concerned is likely to collide with an obstacle in front, To study operation concept, an obstacle concerned and necessary equipment
10	Extensive Range Backing Aid Systems (ERBA)	PWI	System to provide information on an obstacle at a rear end of a vehicle when backing up for a relatively long distance, To study a scope, obstacles concerned, detection areas and system operation conditions, in comparison with MALSO

### [Recent Activities]

#### Themes with draft discussions underway

Regarding MALSO, a standard document was published in July 2004. With Japan serving as a leader, discussions on LDWS have been completed, and it is now in the DIS phase. Smooth progress has been seen in discussions on LCDAS as Japan made a great contribution to test methods, and it is now in the voting stage of DIS draft. NP proposals on FSRA and LSF have been approved, and heated discussions are going on.

**WG14: Vehicle/ Roadway Warning and Control System**

**Themes with new PWI discussions underway**

FCAAS and ERBA have been approved as new PWI themes, launching discussions. FCAAS has already been put on the market, drawing attention from quarters concerned as an advanced safety system. Standardization is expected to promote commercialization. The United States is leading the development of ERBA on the strength of market needs and legal advantages. For its part, Japan will raise questions.

Correlation chart of each theme

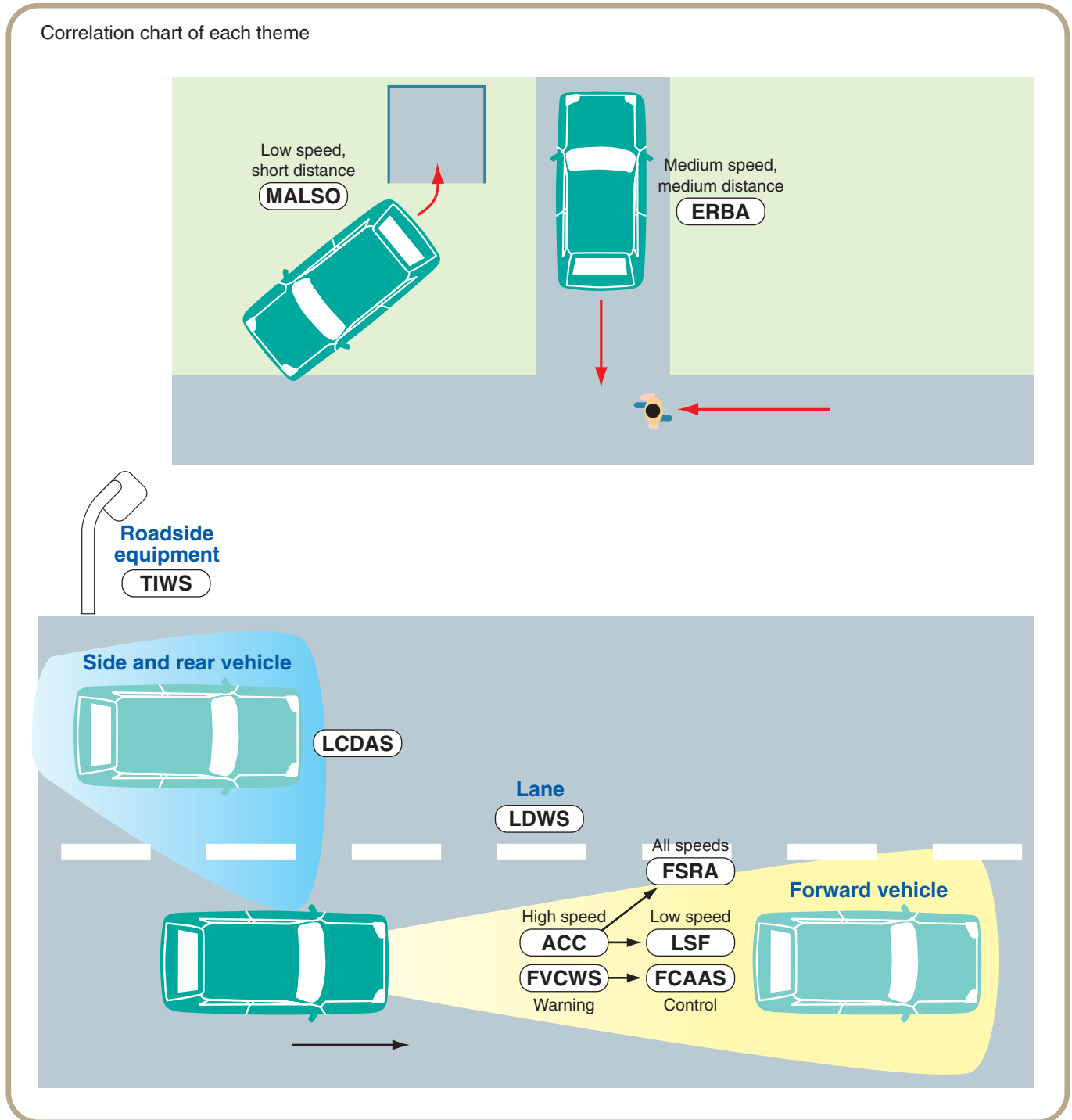

**[Future challenges]**

Standardization is designed to realize an effective and realistic system on a draft. Toward this end, experimental proof is essential, while it is necessary to carry out activities to gain consensus from each country through discussions. Human machine interface(HMI) is very important to realize effective and safety driver support systems. Concerning standardization of HMI a liaison activities with TC22/SC13/WG8 is promoted more tightly.

## Introduction of major work items

### Lane Departure Warning Systems (LDWS)

LDWS is a system to warn a driver of lane departure or of its possibility in consideration for the side location of a vehicle concerned on a lane measured with a lane location detection sensor. Standardization work covers lane departure itself, not judgment of possibility of a collision with vehicles running on the adjacent lane or the content of avoidance control. Japan serves as a leader in draft preparation, which is in the DIS phase.

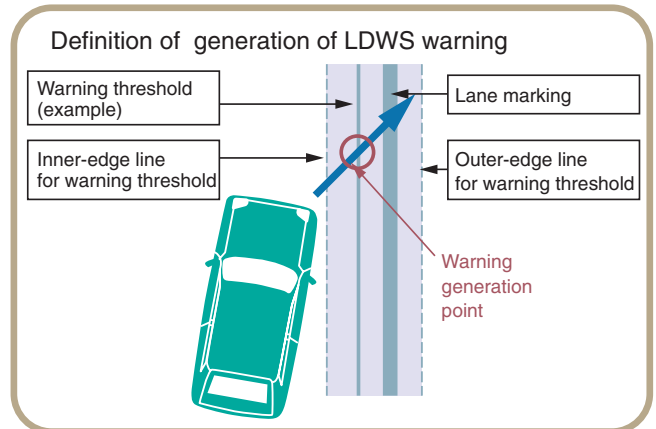

### Lane Change Decision Aid Systems (LCDAS)

LDCAS is a system to give a warning on vehicles running in a blind spot or vehicles approaching from rear side. Deliberations are going on regarding detail warning conditions, such as an existing area of a vehicle subject, existing area of a vehicle concerned, timing of warning (in case a vehicle from the back approaching). This area has many new tasks like testing environment and standard targets. Japan proposes test methods and collects basic data.

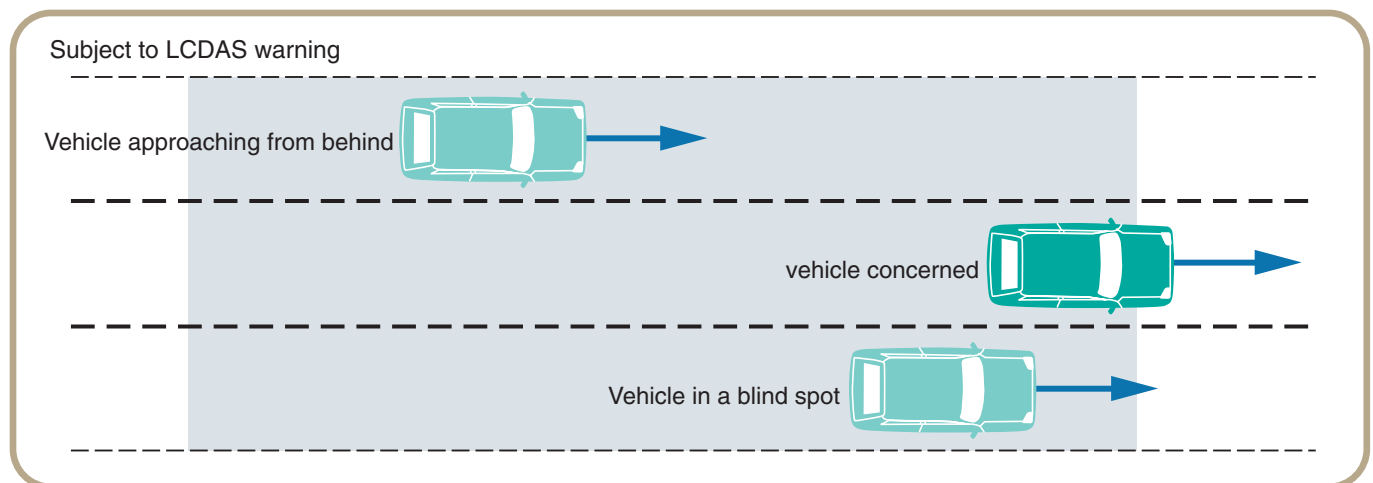

### Forward Collision Avoidance Systems (FCAAS)

A draft of FCAAS includes a system to reduce damage of collision by operating an automatic brake when collision is unavoidable, and a system to avoid collision by operating an automatic brake early when collision is likely. Japan insists on collision mitigation systems, which have been on the market and considered feasible, the United States, a leader of this group, claims that a collision avoidance system is essential. As these systems draw great attention because direct effects are expected on traffic safety, and early international standardization are anticipated. In consideration for movements of ASV and other organizations, comments will be submitted on the basis of domestic consensus and various requirements.

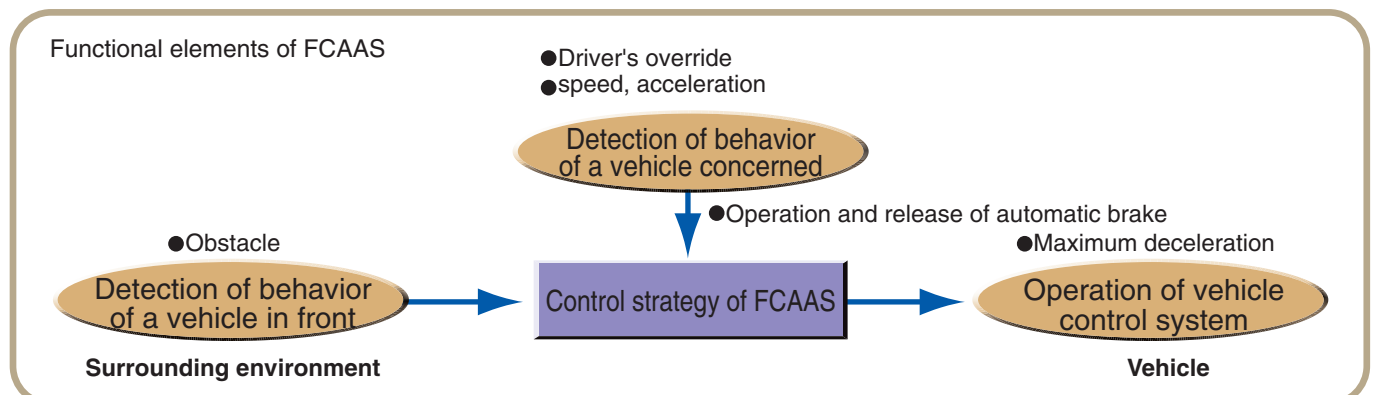

**WG 14: Vehicle/Roadway Warning and Control Systems**

**Extended Range Backing Aid Systems (ERBA)**

ERBA is designed to give a warning on an obstacle at a rear end of a vehicle when it backs up for a relatively long distance. Japan will submit specific proposals on required specifications like detection range and rate, on test methods and standard targets on the basis of radar reflection data of various obstacles.

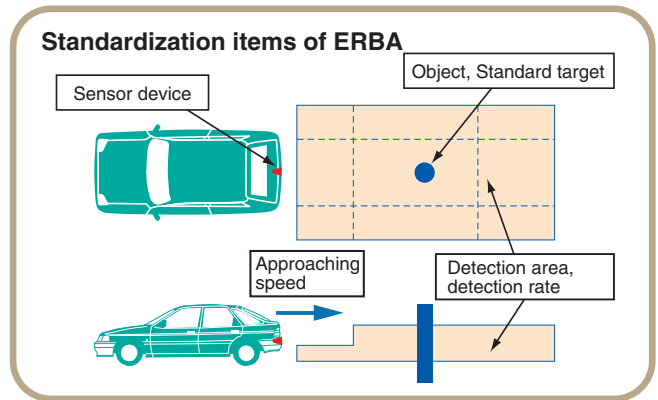

**Low Speed Following Systems (LSF)**

LSF is a system to follow a vehicle running in front on a lane where a vehicle concerned is running in traffic congestion where in principle the process of start-following-stop is repeated. It is designed to reduce load on drivers. Japan suggested that this system is highly likely to be put on the market, and shift to NP was approved. Japan serves as a leader in draft preparation, and is promoting study of detail requirements.

**Full Speed Range Adaptive Cruise Control Systems (FSRA)**

FSRA is a system to extend the operation speed of ACC to the full speed range and keep a distance with a vehicle running in front. When a target vehicle stops, a vehicle concerned comes to stop. Japan will submit problems over functional requirements necessary for expansion, while considering its transport situation.

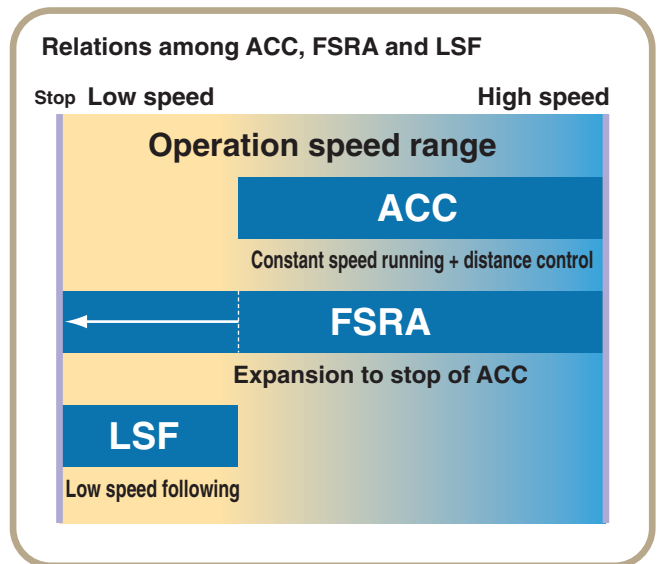

**Major problems over LSF and FSRA**

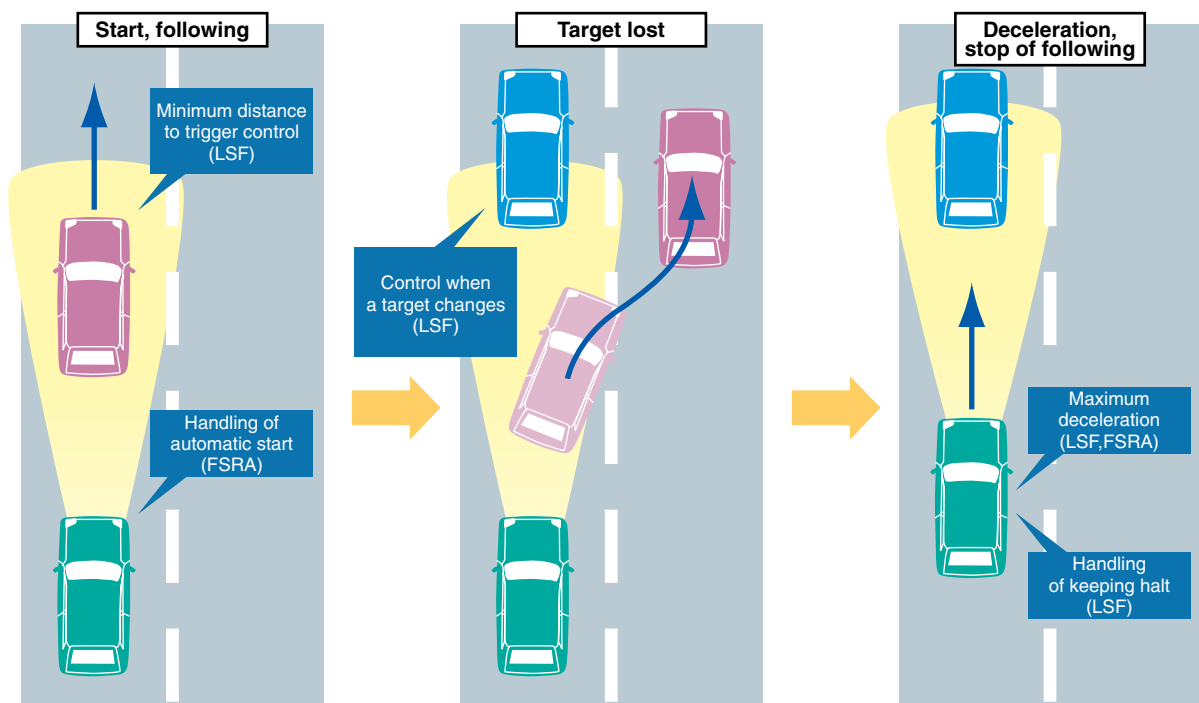

# WG 15: Dedicated Short Range Communications

WG 15 is working on standardization of radio short range communications to be used for ITS applications. This is called Dedicated Short Range Communications (DSRC). The work area is limited to roadside-to-vehicle communications, and the Data Link Layer (LLC sub layer) and the Application Layer in the Open Systems Interconnection (OSI) Seven-Layer Model are subject to standardization.

Standardization of the radio communication method equivalent to the Physical Layer has been handled by ITU-R, and recommendations on methods, including those of Japan and Europe, have been approved.

List of WG 15 work items (as of February 2005)

	Standardization themes	ISO numbers	Contents
1	DSRC Data Link Layer	NP15627	Interface for roadside-to-vehicle communications equivalent to communication protocol Layer 2 (suspended in a bid to include conditions for Data Link Layer in Application Layer draft)
2	DSRC Application Layer	FDIS15628	Interface for roadside-to-vehicle communications equivalent to communication protocol Layer 7 (including part of functions equivalent to Layer 3 - 6)

## Progress in standardization of DSRC

In parallel with international standardization, progress has been made in standardization for DSRC in each country and region. In Europe, 5.8 GHz passive-system DSRC (CEN system) has been adopted as a European standard (EN), while 5.8 GHz active-system DSRC has been formulated in Japan. In North America, study is being made on 5.9 GHz standardization. Many countries are also studying the introduction of these types of DSRC, whereas Italy and South Korea have standardized their own DSRC. DSRC with Infrared systems is also available. As DSRC is a key technology for ITS, priority may be given to the situation of each country.

DSRC protocol generally consists of the Physical Layer, the Data Link Layer and the Application Layer. In Japan, technical specifications on the Application Sub Layer (ASL) have been worked out as upper layers.

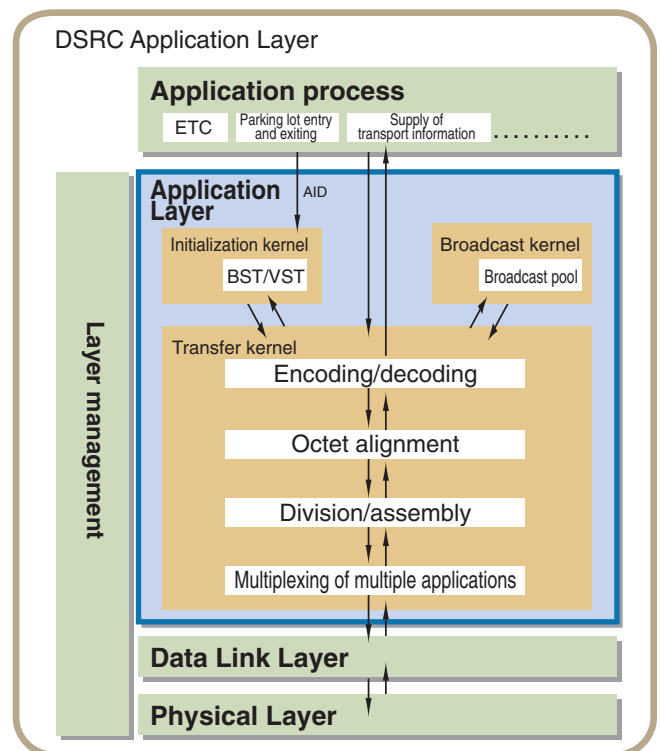
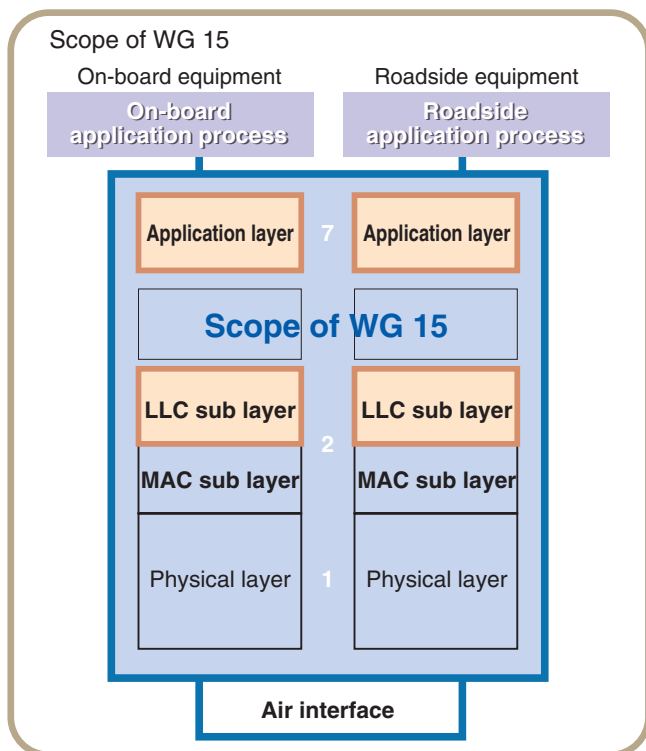

## DSRC Application Layer (FDIS 15628)

Under DSRC, Layers 3- 6 are usually omitted so that a vehicle running at a high speed can carry out direct communication with roadside equipment within a limited communication area. Functions necessary in these layers are included in the Application Layer. Various applications are available in DSRC, and application identifier (AID) identifying applications is stipulated in the Application Layer. Roadside or on-board application processes designate this AID, and carry out communication with the other (on-board or roadside) application processes by way of the Application Layer and lower layers. Communication functions are performed mainly by transfer kernel. The functions include encoding and decoding of information, division and assembly of given frames and multiplexing of application information.

Japan prepared a working draft for this item and completed a draft for committee after incorporating requests from various regions and countries. In 2003, DIS voting was carried out and approved.

# WG 16: Wide Area Communication

## WG 16 Standardization themes

Five SWG (16.0, 16.1, 16.2, 16.3 and 16.4) are working on standardization at WG 16. Work can be divided into Communication Air-Interface, Long and Medium Range (CALM) areas and probe areas.

List of WG 16 work items (as of February 2005)

	Standardization themes	ISO numbers	Contents
1	Protocol management information	FDIS15662	Message management information of ITS applications in medium and wide area communication systems between a service center and a user terminal
2	CALM system architecture	NP/CD21217	Study on architecture of Communication Air Interface, Long and Medium Range (CALM), status of NON-CALM media (SWG 16.0)
3	CALM-2G, CALM 3-G (2nd and 3rd generation cellular phones)	NP21212 NP21213	AP interface using 2nd and 3rd generation cellular phones and the mobile Internet for ITS (SWG 16.1)
4	CALM-IR (infrared)	DIS21214	Application interface using infrared medium and wide area communication systems for ITS (SWG 16.1)
5	CALM-M5 (5 GHz-band ITS communication)	NP21215	Communication interface for ITS communication related to protocol 5 GHz band, Actual study by IEEE 802.11 Task Group (SWG 16.1)
6	CALM-MM (millimeter wave)	NP21216	Standardization theme when millimeter wave medium and wide range communication is used for ITS (SWG 16.1)
7	CALM-NW protocol	NP21210	Handover of medium and wide area communication, conditions for service access points (SAP), standards related to media selection function (cooperation with IEEE P 1609) (SWG 16.2)
8	CALM-LL-SAP	NP21218	Interface for each media to access the 3rd communication layer (IP layer) (SWG 16.1)
9	Probe data	NP22837	Standards of information transmitted from a vehicle to an information processing center (SWG 16.3)
10	CALM-PPM	PWI	Study on DSRC adopting FDIS 15628 (DSRC-L7) including ARIB and use of CALM communication media combining T88 ASL (application sub layer) (SWG 16.1)
11	CALM spectrum management	PWI	Function for continuous running in areas of different frequencies (SWG 16.1)
12	Probe personal information protection	PWI	Basic principle of protecting personal information in probe information services (SWG 16.3)
13	CALM-AM (application management)	PWI	To study the installation of applications on ITS radio communication units and work out conditions for external interface (SWG 16.4)

## What is CALM?

Long and Medium range, high speed, air interface parameters and protocols for broadcast, point-point, vehicle-vehicle, and vehicle-point communications in the ITS sector

- Supports ITS services and internet services
- Supports continuous communication at a time of handover from one medium to another
- Covers differences between communication media and providers
- Realizes various communication modes
- No influence on existing communication media
- Affinity for existing communication media

## SWG 16.0: CALM architecture

CALM architecture was launched initially as internal work in CALM discussions in order to clarify each theme and term of CALM. As study themes of CALM have been expanded, CALM architecture has become a new standardization theme. DIS is scheduled for August 2006.

General purpose: capable of using applications and services (Web, etc.) on the Internet with IP protocol and direct access to the Internet

Continuous communication: capable of using several media, such as cellular phones, infrared, 5 GHz band DSRC, and millimeter waves, and of handover among these media

Large capacity: Capable of several Mbps communication capacity depending on media (3-6 Mbps for M5, a 5 GHz medium)

General framework and positioning of CALM architecture

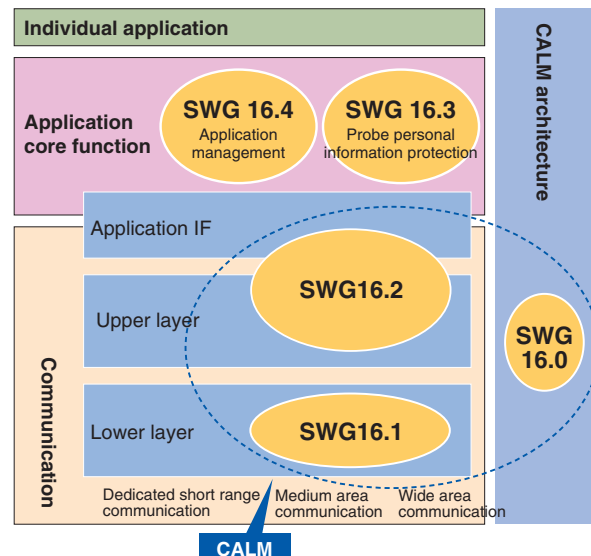

## General structure of CALM

CALM has an access interface SAP (service access point) between the 2nd layer and 3rd layer, making access to the IP layer (3rd layer) possible from various media such as cellular phones and millimeter waves. Under CALM architecture, media other than those not regulated at the moment are also capable of access to 3rd layer (network layer), a premise of CALM. Also scheduled for study is vehicle-vehicle communication under CALM.

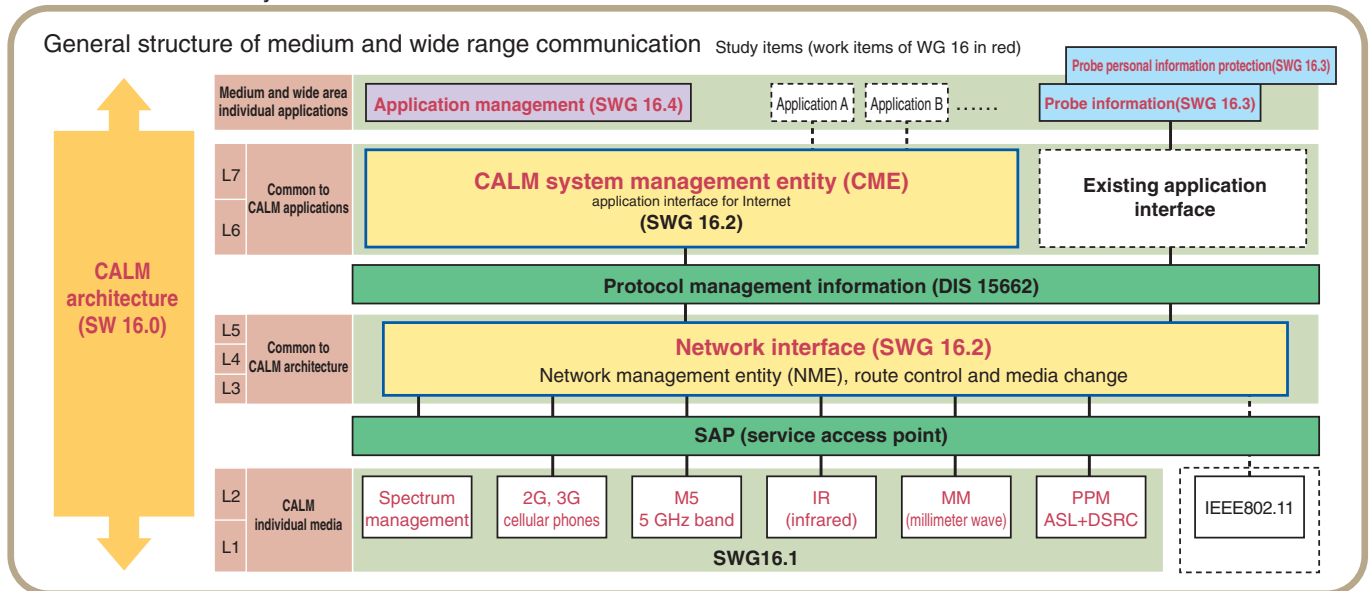

## SWG 16.1: CALM media (lower layer)

Multiple media are capable of using CALM, and new media will be added, depending on future progress in technology or changes in demand.

### CALM-M5 (SWG 16.1)

Among the presently possible CALM media, M5 using radio LAN technology is expected to play a central role.

In November 2004, work of IEEE 802.11p was launched as an official task group of IEEE 802.11. Progress is being made in standardization as a DSRC media of the United States and as a media of ISO-CALM.

### CALM-IR (SWG 16.1)

A draft is being prepared under the leadership of Austria and Germany. In Germany, CALM-IR will be employed to prevent illegal use of a system using cellular phones and GPS for charging of heavy vehicles. It is quite different from the optical beacon system using infrared now in wide use in Japan.

### CALM-MM (SWG 16.1)

In November 2002, an editor was selected from Japan at a WG 16 conference. Study has been made on related system cases, characteristics and standardization requirements of millimeter wave communication and applications, and standardization scope. It is now in the NP phase.

### CALM-2G, 3G (SWG 16.1)

Work will be promoted in cooperation with ITU-R and ETSI with a view to standardization of AP interface using the 2nd and 3rd generation mobile communication and the mobile Internet for ITS. In October 2004, one-year extension of the NP work was approved at a TC 204 meeting in Beijing.

### CALM-spectrum management (SWG 16.1)

Considering the likelihood that media in multiple frequencies will be used simultaneously, it is necessary to reduce mutual interference of radio waves as much as possible. CALM spectrum management is aimed at coordination of output of each antenna in order to decrease interference to the lowest possible. Of course, this is premised on the observance of legal systems of each region and country on frequency and output of radio waves.

### CALM-PPM (tentative name) (SWG 16.1)

As medium of the 5 GHz band, DSRC of the 5.8 GHz band, including ARIB and STD-T75 of Japan, is under development or in operation in various countries and regions.

Standardization of the 7th layer (application layer) of DSRC is being worked out as FDIS 15628. It has been proposed that a new 5 GHz-band media be accessed to CALM (accessed to a CALM network). If approved, it will be possible to use as CALM media DSRC devices already verified for their operation and those to which frequency spectrum has already been assigned.

Regarding applications to be developed in the future, compliance with FDIS 15628 for the 7th layer (application layer) of DSRC will make it possible to use CALM media.

WG 16: Wide Area Communication

# SWG 16.2: CALM Network (Upper Layer)

## What is the standard for the CALM network (NP 21210)?

This standard will provide a function to realize seamless communication environment (handover among the same media and media changes, etc.), which is a major concept of CALM.

In application development, a platform using CALM environment will be provided regardless of expertise on communication media and networks. Consideration is given to Internet IPv6.

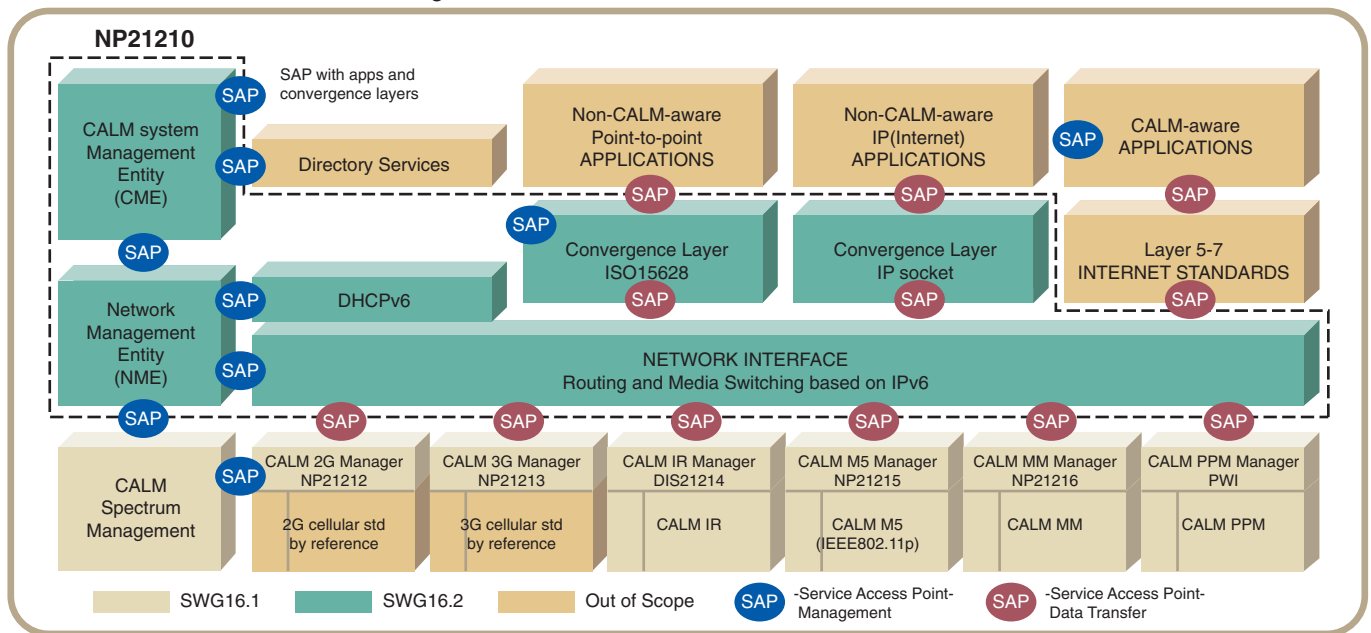

## Three communication scenarios of CALM

### [1] Scenario 1

Under this scenario, CALM is supposed to be used in areas that require high-speed processing, including safety-related applications, on the premise of one-on-one communication. No consideration is given to Internet access. Views will be compiled with reference to the study of IEEE P1609 and CALM-IR.

### [2] Scenario 2

This scenario uses Internet access. No attention is paid to distribution of information by push technology to vehicles from a media switch or the Internet. In case the scenario 2 and 3 are available for equipment, it depends on quarters concerned (users, vendors and service providers) which will be used. Views will be compiled on the basis of the study of IEEE P1609.

### [3] Scenario 3

Possible will be complete Internet access, including a media switch. Also available will be distribution of information by push technology from servers. Japan is playing a leading role in this study.

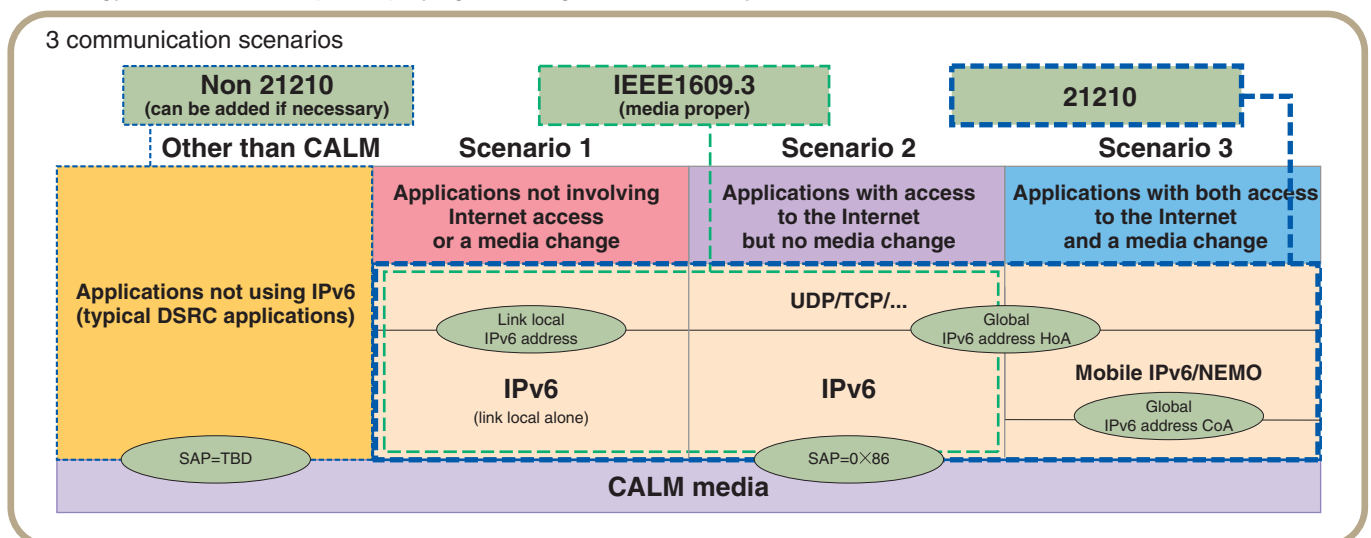



### Media selection through CALM-CE

Study is being made as a standard for CME (CALM System Management Entity) regarding a function to select an appropriate media by comparing requirements for media from applications, and condition and characteristics of media.

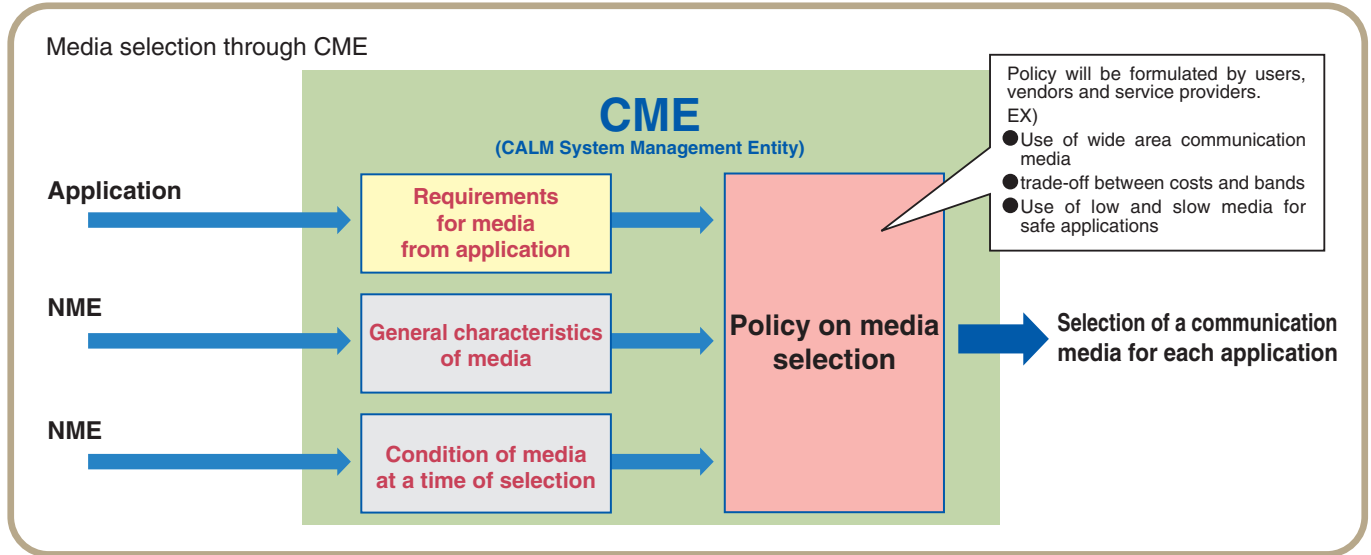

## SWG 16.3: Probe data

### Standardization of probe data

This group is in charge of standardization for a reference model, a data structure model and information categories regarding collection of probe data (various information obtained from vehicles) using medium and wide area radio communication. A probe message serves as a container carrying various probe data with a location stamp and a time stamp.

Consideration is given to the followings in promoting standardization.

- Fundamental framework in the application layer
- Uplink information from a vehicle to a center
- Basic definition and extension mechanism

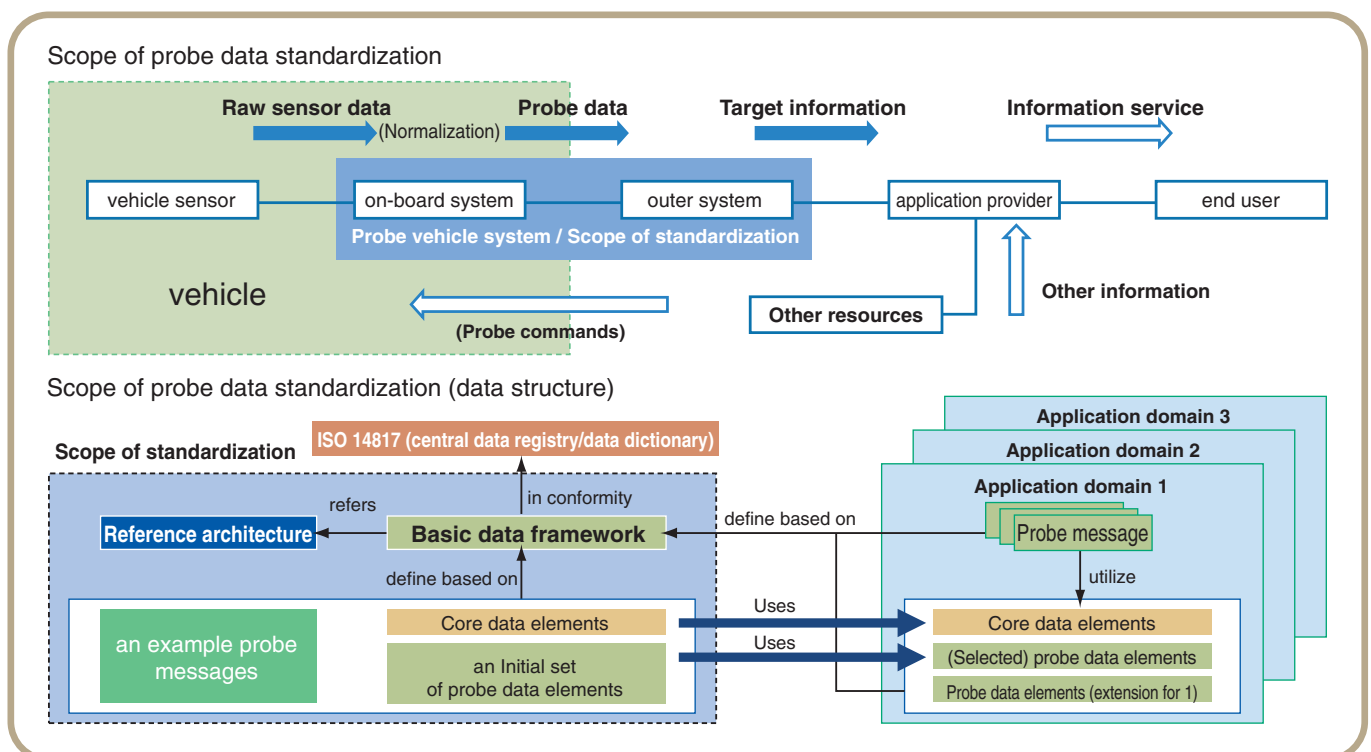

## WG16: Wide Area Communication

### Personal Data Protection in Probe Vehicle Information Services

● In probe information services, the relationship between usefulness of probe information and handling of personal data is an extremely important problem for all the quarters concerned, such as probe data suppliers, probe vehicle information service providers and information users. Personal data cannot be handled too carefully.

● Following are considered personal data handled by probe vehicle information services: “contract registration information with a probe data suppliers,” “communication ID,” “password for certification,” “communication log” and “personal data included in probe data itself.”

● Pursued are “preparation of guidelines to be followed by the quarters concerned” and “standardization of design guidelines necessary for its achievement” in addition to observance of laws concerning personal data protection, so that probe data suppliers can provide probe data with no worry.

● It will be quite difficult to establish a uniform standard because legal systems on personal data protection differ from country to country. Therefore, priority will be given to consensus for the need for international standards and narrowing down of standardization items. “Specification of probe vehicle information services and limitation of services,” “clarification of requirements for probe vehicle information systems” and “concentration of priority items for wide use of probe vehicle information services.”

## SWG 16.4: Application Management

### What is application management?

It is a system to download applications and data from outside sources and realize new application services for equipment with ITS radio communication functions (roadside equipment and on-board equipment for ITS applications).

### Objective and scope of standardization

The objective of standardization is to study how to realize installation of applications on equipment related to ITS radio communication. Subject to standardization are systems and methods to add, update and delete applications.

Also subject to study are application management interface conditions (external interface, communication conditions, file control, security control and application priority control).

There will be room for leeway for development and manufacturing of related equipment.

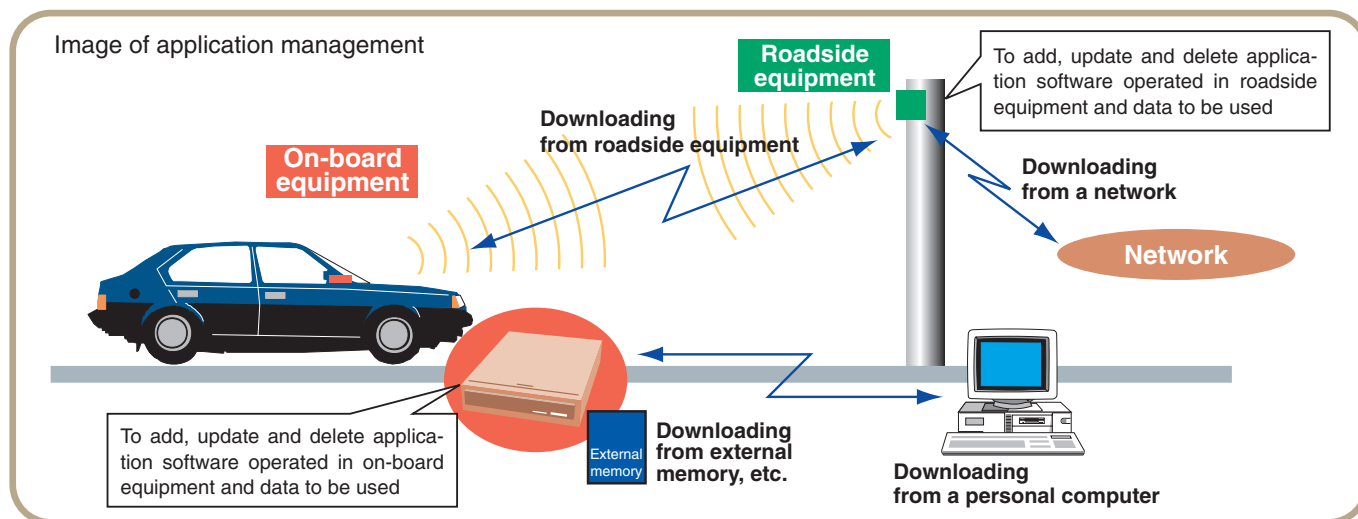

## Protocol Management Information (FDIS 15662)

Displayed are information items necessary when data is exchanged using medium and wide area communication in ITS applications. The information is designated as meta-information (attribute information) of a message defined by each WG of TC 204, and serves as a check list designed to realize a system to process the message.

- Selection of information systems (responsiveness, directivity, configuration, service area, service hours, band, access cost)
- Application identifier (message ID, message number, message transmission time)
- Address (sender and receiver)
- Priority (interrupt processing, delay control)
- Security (mutual certification, data certification, concealing)
- Application execution (appropriate time, time stamp, scope)

As a result of DIS voting in October 2003, it was decided to turn protocol management information into ISO.

# System Human Interface Subcommittee

## Background and objective

With ITS deployment, the number of machines to be operated and information supply units is increasing, which is likely to increase work load on drivers. This subcommittee is working on standardization of human machine interface (hereinafter referred to as HMI) designed to reduce work load to the minimum and promote safety with simple operations. It is also facilitating research related to future HMI and preparing scenarios for standardization.

At the time when TC 204 was founded, WG 13 (Human Factors and MMI) was set up to take charge of standardization of HMI of an entire ITS system, including infrastructure. In 1998, however, activities for international standardization were integrated into TC 22 (road vehicles)/SC 13 (Ergonomics)/WG8 (TICS on-board MMI). This committee holds a meeting with the same members as the “human interface subcommittee” equivalent to TC 22. This means it implements activities as TC 22 handling HMI of on-board ITS units and as TC 204 dealing with HMI of an entire ITS system, including infrastructure.

TICS : Transport Information and Control System

## Outline of activities

Discussions on many items have been completed, and study has already been launched on new standardization items. Under discussion are items having great influence on ITS, such as driver distraction.

List of TC22/SC13/WG8 work items (as of February 2005)

	Standardization themes	ISO numbers	Contents
1	Dialogue management	ISO15005	Human engineering principles and conformity standards regarding dialog management of on-board ITS units while driving
2	Auditory information	FDIS15006	Recommendation items and measuring conditions concerning ITS information supply through hearing, FDIS approval obtained, IS to be issued soon
3	Visual behaviour	ISO15007-1	Analysis and measuring methods for visual behavior of drivers
		TS15007-2	Part 1: Definition of terms and standardization of parameters, Part 2: standardization of testing equipment and methods
4	Visual presentation	ISO15008	Requirements and evaluation of ITS visual information display, including variable message boards
5	Suitability	ISO17287	Assessment of suitability during operation of ITS system
6	Priority	TS16951	Methods to determine priority when providing multiple data, including ITS, to drivers
7	Visual distraction	CD16673	Testing of visual operation capacity of navigation systems and others while running
8	Warning systems	TR16352	Compilation of preceding study cases on how to give a warning, Issue as TR
9	Warning Integration	WD	Stipulation of general definition and requirements of warnings, WD is being prepared on the basis of scope and standard document outline
10	Simulated Lane Change Test	Under preparation for PWI	Evaluation of driver distraction occurring when operating ITS equipment under a lane change test
11	Participant Characteristics	Under preparation for PWI	Stipulation of requirements and selection of subjects in accordance with the objective of experiments, Direction of standardization is under discussion

## Main items under discussion

### Visual distraction

This stipulates testing methods regarding allowable standards for operation of equipment requiring visual recognition, such as navigation systems. It has been agreed to use a method called “occlusion” and not to include criteria in standards because transport situation differs from country to country. At each meeting, results of study using occlusion are submitted, and heated discussions are going on. It has recently been agreed to set the opening time of a shutter preventing visibility at 1.5 seconds and the closing time at 2 seconds.

### Warning integration

This is designed to prescribe definition and classification of warnings and how to give them. Its work was launched at the proposal of TC 204/WG 14. Japan and the United States serve as co-leaders. Japan has submitted a proposal for scope and standard document outlines in a bid to designate warning integration as a standard to realize “driver-centered design.”

### Driver distraction

This is intended to standardize evaluation methods for distraction, including voice operations. Sweden is playing a leading role with many countries taking part in discussions. Under study is a lane change test method proposed by Europe. Problems arise over differences in sensitivity from occlusion and coordination of evaluation results. It may take a little more time to turn it into NP.

- Driver distraction means that a driver's attention is distracted from objects for safe driving to those not related to driving. Looking aside while driving is called visual distraction.
- Warning integration means providing human interface conditions to integrate information issued from several warning systems simultaneously so that a driver can respond to warnings appropriately.

# ISO/TC 204

## International Standards established

### ISO international standards issued so far (as of February 2005)

<b>WG1</b>	<b>ISO14817</b>	<b>Requirements for an ITS/TICS central Data Registry and ITS/TICS Data Dictionaries(December 2002)</b> To stipulate a system to register and manage as a common dictionary definitions of standard data used widely among ITS systems
<b>WG3</b>	<b>ISO14825</b>	<b>Geographic Data Files (GDF) (February 2004)</b> Standard for data exchange of geographical database used for navigation systems. If they are expressed in the format of this standard, map data prepared all over the world can be distributed as data for navigations systems among map vendors.
<b>WG5</b>	<b>ISO14906</b>	<b>Electronic fee collection-Application interface definition for dedicated short-range communication (September 2004)</b> To regulate EFC application interface under the DSRC method. This standard has been adopted for ETC on-board equipment and roadside equipment in Japan and many European countries. The number of ETC on-board equipment reached 3.77 million as of September 2004
<b>WG10</b>	<b>ISO14819-1</b>	<b>TTI messages via traffic message coding-Part 1:coding protocol for Radio Data System (June 2003)</b> To stipulate introduction of the RDS-TMC (message coding of traveler information through FM broadcasting) system. It is possible for a divers to receive transport information in their native tongue with use of a virtual language even when they pass a border
<b>WG10</b>	<b>ISO14819-2</b>	<b>TTI messages via traffic message coding-Part 2:Event and information codes for Radio Data System (June 2003)</b> Compilation of traveler information messages used for the RDS-TMC system. To stipulate how to codify event information. A central standard in the 14819 series, it has made great contribution to ensuring interoperability of message exchange between different systems.
<b>WG11</b>	<b>ISO15075</b>	<b>In-vehicle navigation systems-Communications message set requirements (December 2003)</b> To stipulate necessary items for a message set handled by an on-board navigation system Prepared on the basis of existing standards in Japan and North America, it has specifications applicable to the route guidance system
<b>WG14</b>	<b>ISO15622</b>	<b>Adaptive Cruise Control Systems (ACC) (October 2002)</b> To stipulate the minimum and recommended headway time and automatic brake performance on the basis of transport surveys in Japan, the range of detection of a vehicle running in front in view of man's response time. To prescribe evaluation and standards in detail for performance of actual systems in various driving environments. (JIS in 2000)
<b>WG14</b>	<b>ISO15623</b>	<b>Forward Vehicle Collision Warning Systems (FVCWS) (October 2002)</b> To stipulate system performance after the study on scope of detection of a vehicle in front in view of human's response time and warning issue accuracy on the basis of the draft prepared by Japan. Wrong warnings are reflected in evaluation and standards in various driving environments. To describe in detail items regarding human interface, such as display of warnings. (JIS in 2000)
<b>WG14</b>	<b>ISO17386</b>	<b>Manoeuvring Aids for Low Speed Operation (MALSO) (July 2004)</b> Research was made into system performance evaluation tests and test subjects used to reflect back sonar and other equipment now being put on the market in Japan in the initial standard draft.

### ITS-related JIS Table

WG	Title	JIS	JIS (TS)	JIS (TR)	JIS Number	Corresponding ISO Number
1	Glossary of ITS terminologies		x		TSD 0001:2005	14812
1	ITS Reference Model Architecture-Part1: ITS Fundamental Services		x		TSD 0002-1:2005	14813-1
1	ITS Reference Model Architecture-Part2: Core ITS Reference Architecture		x		TSD 0002-2:2005	14813-2
1	ITS Reference Model Architecture-Part3: Requirements for Architecture Description in ITS Standards		x		TSD 0002-3:2005	14813-5
1	ITS Reference Model Architecture-Part4: Data Presentation in ASN.1		x		TSD 0002-4:2005	14813-6
1	ITS On-board system architecture			x	TRD 0003:2001	
3	Map data physical storage format for car navigation systems	x			JISD 0810:2004	
14	Adaptive Cruise Control Systems	x			JISD0801	15622
14	Forward Vehicle Collision Warning System	x			JISD0802	15623
14	Evaluation method for driver acceptance of advanced driver assistance systems		x		TSD 0005:2005	

# Introduction of related international standardization activities

## ISO/TC 211(Geographical information/Geomatics)

TC 211 is in charge of standardization of geographical information. This work aims to establish a structured set of standards for information concerning objects or phenomena that are directly or indirectly associated with a location relative to the earth. TC 211, established in 1994, is chaired by Norway. In Japan, the “Japan National Committee for ISO/TC211” has been established in the Association of Precise Survey and Applied Technology. In many cases, TC 204 handles information related to location. In this sense, TC 211 is closely connected with TC 204.

### Standardization activities by TC 211

TC 211 has developed some 20 conceptual and systematic standards for design of geographical information, quality, spatial referencing system, meta-data, and services. At the finalization of these standards, TC 211 disbanded 4 out of 5 WGs, and established new 4 WGs in October 2001. At present, it is developing implementation-level standards and expanding existing standards. Specifically, it is working on expansion of standards to geographical images, web services of geographic information and Location-Based Services (LBS). For detailed work items, please refer to the homepage of ISO/TC 211 ([www.isotc211.org](http://www.isotc211.org)).

From the early stage, TC 211 adopted UML and XML as standard notations because geographic information is one of information .

### Location-Based Services (LBS)

LBS refers services combining map information, positioning services and external information concerning location of moving objects. As an application area of geographical information, LBS is expected to become a larger market than GIS. Possible specific application areas are disaster management, rescue of victims and intelligent routing. TC 211 of WG 8 is working on standardization of “LBS—reference model,” “LBS—tracking and navigation” and “LBS—multimodal routing and navigation.”

Figure: LBS Interface schema and standardization items

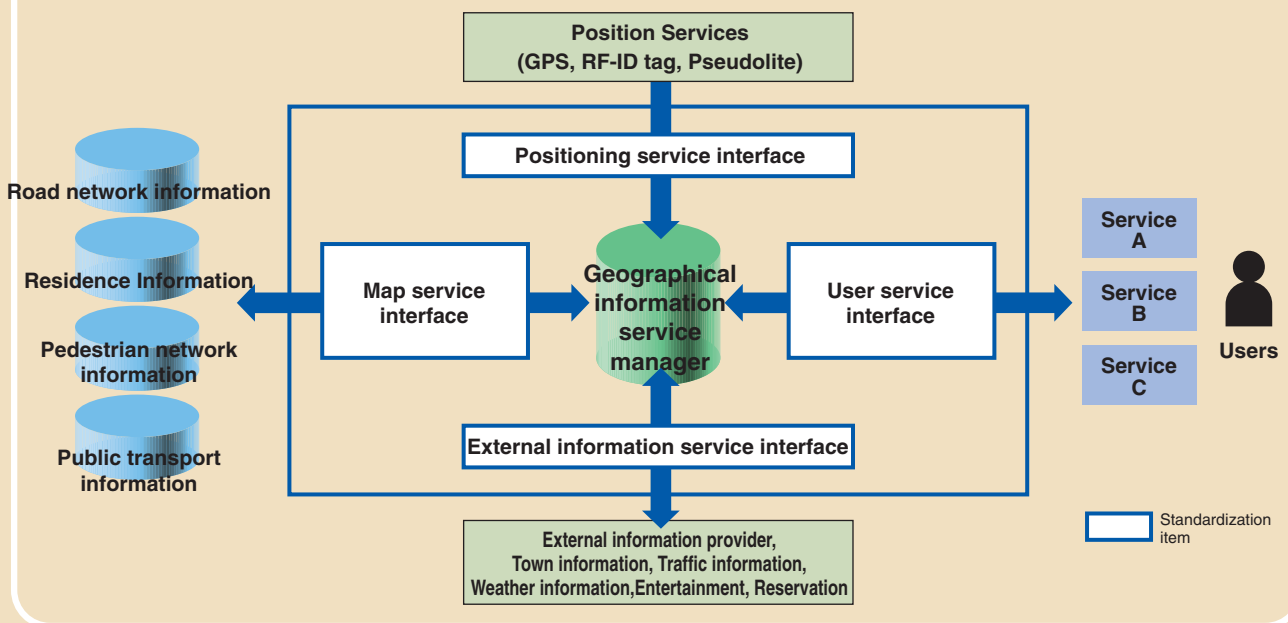

### Cooperation between TC 211 and TC 204

Since its inception, TC 211 has had liaison relations with TC 204. In 2004, a new cooperative agreement was concluded between TC 211 and TC 204 for even closer collaboration for LBS on the TC 211 side. Specifically, TC 211 and TC 204 have established a joint task force to share documents, ensure compatibility and jointly develop standards if a need arises. Another role of the joint task force is to promote coordination among standards using UML models.

# Introduction of ITS standardization activities

## ISO/IEC JTC1 SC31

### (Standardization activities for technologies of automatic identification and data capture)

JTC1 SC31 is involved in standardizing the AIDC (Automatic Identification and Data Capture).

AIDC is defined by ISO as “methods and technologies to identify 'objects' without human intervention”, which is mainly utilized as measures for supply chain management.

The standardization of SC31 involves 5 working groups. WG1 is working on standardizing 1st-dimension and 2nd- dimension symbols, WG2 on methods of data-storage to data carrier, WG3 on conformance, and WG4 on RFID respectively. Each working group is finalizing the development of standards. Focus is being shifted toward the future to WG5 (Real Time Location System) which was newly established in 2004. RTLS is a system to identify the location of objects based on the RFID technology. This system will be closely related to TC304 since the link with GPS is considered.

## Standardization of RFID

WG4 which plays the role of standardizing has almost completed the scheduled task for developing standards (Fig. 1). In the future, the major themes will be coordination with the EPC global tag which is planned to be used by the Wal-mart and the National Ministry Establishment. There are 3 themes. The first one is the way to coordinate with ISO/IEC 18000-6 (860 to 960MHz), existing standards for air interfaces. According to the EPC global plan, It will be proposed as ISO/IEC 18000-6 type C. The second one is the problem regarding IP, where all RFIDs are license technologies contrary to barcode. The third one is the problem regarding product identification code system, i.e. the measures to construct a meta-code system which is represented by the EPC global code system, other RFID code systems, code systems for 1st dimension and 2nd dimension symbols, and the link with an EDI identifier. WG2 is also deeply involved in this problem. In this situation, Japan came forward as a candidate for the convenor of WG2 to take the leadership in this field.

Fig. 1 Details of Standardization (WG4 for RF tag)

Title	P-No.
Radio Frequency Identification for Item Management-Air Interface Part 1 - Generic Parameters for Air Interface Communications for Globally Accepted Frequencies	ISO/IEC 18000-1
Part 2 - below 135KHz	ISO/IEC 18000-2
Part 3 - 13.56MHz	ISO/IEC 18000-3
Part 4 - 2.45GHz	ISO/IEC 18000-4
Part 5 - 5.8GHz	ISO/IEC 18000-5
Part 6 - 860-930MHz	ISO/IEC 18000-6
Part 7 - 433MHz	ISO/IEC 18000-7

## SCM standards for RFID

Supply chain is composed of diversified forms. Therefore, identification methods corresponding to each form and the consistency in information between forms are both significant. (Fig. 2 and Fig. 3) As well as the consistency in information, there is another problem regarding air interfaces between layers. For example, a case using the interface of ISO/IEC 18000-3 (13.56MHz) for layer 0 with ISO/IEC 18000-6 for a collective unit, and on the contrary, a case where different interfaces are used in each layer. Thus, there are many themes to examine. America maintains the same interface (ISO/IEC 18000-6) all through layer 0 to layer 3. In this case, a theme is the method for verifying the demerit in this environment.

Fig.2 Layers of Supply Chain Management (Transport unit)

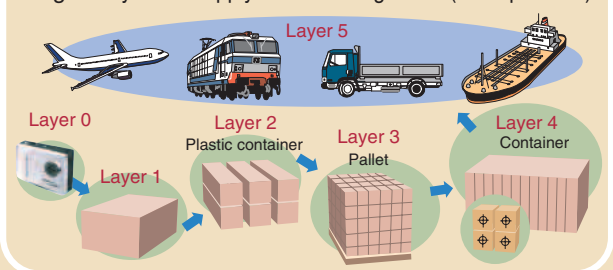
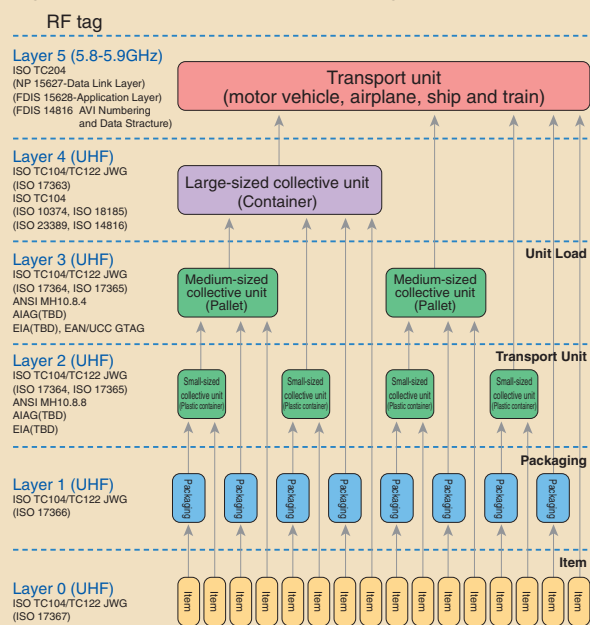

Fig. 3 Layers of Supply Chain Management



## ITS-related Standardization in IEEE

As one of standardization activities in IEEE (the Institute of Electrical and Electronic Engineers), the IEEE 802 Committee is involved in standardization of technologies regarding LAN (Local Area Networks) and MAN (Metropolitan Area Networks). In ISO, technological standards prepared by the IEEE 802 Committee are often adopted as those in the area of LAN. Within the IEEE 802 Committee, working groups are involved in activities by the targeted area such as standardization of Ethernet in 802.3WG. In the area of wireless systems, 6 WGs of 802. 11, 15, 16, 20, 21, 22 are presently involved in the activities for standardization.

Among these groups, 802.11WG, which is promoting the standardization for wireless LAN technologies, has task groups by the targeted area as shown in the table below. The IEEE802.11b specifications of which TGb prepared is well-known.

Task groups in 802.11WG

Task groups	Scope of project	Status
TGa	Creation of specifications for physical layer of 5GHz band	Completed
TGb	Creation of specifications for physical layer of 2.4GHz band	Completed
TGe	Expansion of MAC specifications for QoS	Active
TGf	Creation of specifications for communications between access points (AP)	Completed
TGg	Expanded specifications for 802. 11b, High-speed version of 2.4GHz band	Completed
TGh	Expanded specifications for 802. 11a (for European region)	Completed
TGi	Expansion of MAC specifications for security	Completed
TGj	Creation of specifications for the use of 4.9-5GHz in Japan	Completed
TGk	Creation of specifications for the acquisition of wireless resource information	Active
TGm	Amendment of specifications such as 11a, 11b, etc.	Active
TGn	Creation of specifications for next high-speed wireless LAN	Active
TGp	Creation of specifications for road-to-vehicle and vehicle-to-vehicle communications in 5.9GHz band, North America	Active
TGr	Expansion of MAC specifications for high-speed roaming	Active
TGs	Creation of specifications for communications to construct a network with mesh structure	Active
TGT	Specifications of test method for wireless LAN	Active
TGu	Creation of specifications for communications with networks other than wireless LANs	Active
TGv	Creation of specifications for managing wireless resource information	Active

A communication system applied to 5.9GHz band (5.85-5.925GHz) allocated to ITS in North America is called WAVE (Wireless Access in Vehicular Environment). In this context, standardization activities for physical layer and MAC layer were launched in November 2004 as TGp. In TGp, standardization is examined based on the ASTM (American Society for Testing and Materials) standard E2213-03.

In WAVE, applications which are unique to ITS such as safety are assumed, and standardization work for layers higher than MAC layer is promoted in IEEE1609 in coordination with each other to realize functions such as channel control, resource management, etc. At present, examination work is progressing toward the targeted communication architecture as shown below.

Architecture of WAVE

SNMP (IEEE P1609.3, RFC3412)	Applications	Applications	Applications
	Resource Manager (IEEE P1609.1)	Resource Services (IEEE P1609.2)	
SME (IEEE802.11) /WME (IEEE P1609.3)	UDP(RFC768, IEEE P1609.3)		
	IPv6, Networking Services(RFC2460, IEEE P1609.3)		
	LLC(IEEE802.2, IEEE P1609.3)		
	Channelization(IEEE P1609.4)		
	MLME (ASTM E2213)	MAC(ASTM E2213)	
	PLME (ASTM E2213)	PHY(ASTM E2213)	

# Introduction of ITS standardization activities

## ITS-related standardization in ITU

### What is ITU?

Public organizations to create International Standards are ISO (International Organization for Standardization), IEC (International Electrotechnical Commission) and ITU (International Telecommunications Union). Besides these three major organizations, there is JTC1, a joint committee of ISO and IEC. Main areas for them to cover are as shown in the figure below. International standards regarding the ITS is deliberated in ISO/TC204. ITU-R prepares recommendations regarding the ITS radio communications.

Areas covered by public organizations

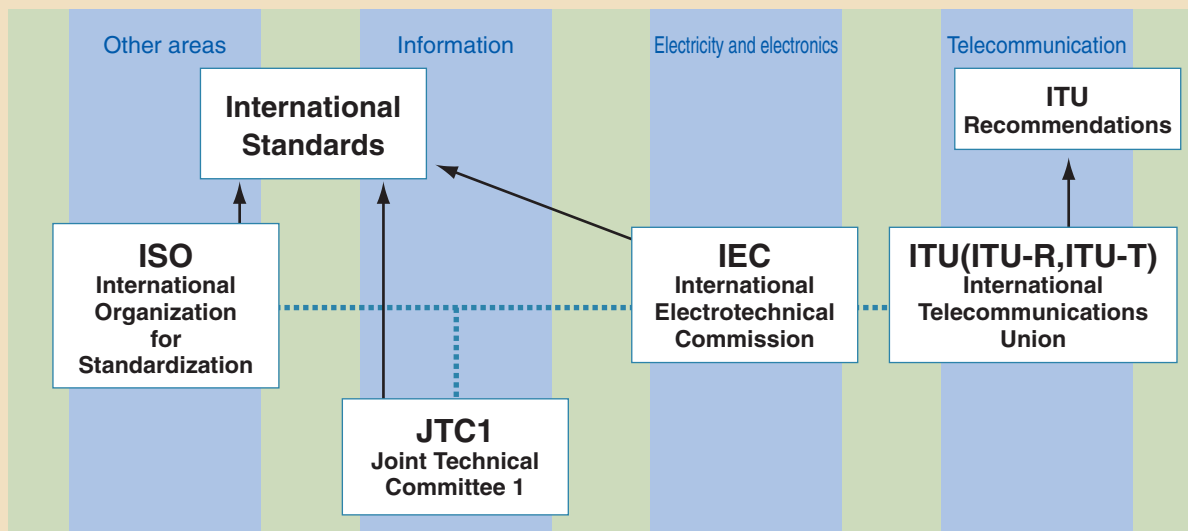

ITU was established in Paris in 1865. After World War II, it was shifted to an organization of the United Nations as it is now. The headquarters is in Geneva with the member countries and organizations as of December 2004 at 189 and 625 respectively. ITU is the organization where governments from many countries and private organizations work together toward the development of telecommunication technologies and to coordinate with world communication networks and communication service operations.

In radiocommunications, this organization is involved in adopting international regulations and international treaties regarding terrestrial and space (satellites) frequency allocations and orbital position of geostationary satellites. Each country must legislate domestic rules based on the above rules. ITU also bears various roles such as development of standards to secure worldwide interconnectivity in telecommunication and technical support to developing countries. The organization of ITU is as shown in the table below.

Organization of ITU

Plenipotentiary Conference		
WRC (World Conferences on International Telecommunications) <b>RA (Radiocommunication Assembly)</b> SG (Study Groups)	World Telecommunication Standardization Assemblies SG (Study Groups)	World/ Regional Telecommunication Conferences SG (Study Groups)
Telecommunication Bureau	Telecommunication Standardization Bureau	Telecommunication Development Bureau
<b>ITU-R</b> (Radiocommunication Sector)	<b>ITU-T</b> (Telecommunication Standardization Sector)	<b>ITU-D</b> (Telecommunication Development Sector)



The organization involved in standardization of radiocommunication is the Radiocommunication Assemblies (RA) of the Radiocommunication Sector. Recommendations, i.e. communication standards, are prepared by the Radiocommunication Study Groups, subordinate bodies of RA. Presently, radiocommunication study groups have several study groups and related committees. Among them, a group which has the closest relation with ITS is the study group called SG8 (Mobile, radiodetermination, amateur and related satellite services). SG8 also has several working parties (WP) as subordinate groups. Among these parties, WP8A (Land mobile service excluding IMT-2000; amateur and amateur-satellite service) is involved in standardization activities for ITS.

## Standardization of ITS in ITU-R

Standardization of ITS in ITU-R was launched through the proposal of TICS (Transport Information and Control Systems: currently renamed as ITS) in 1994 as a study question. In 1995, the study question was officially adopted. The recommendation is positioned in ITU-R as the answer for the question. Intensive works have been done on the ITS study question since 1995. In 1997, "Objectives and Requirements" which describes requirements of radiocommunication in ITS was approved as a recommendation. This recommendation is a high-level document to describe the architecture of ITS radiocommunication in ITU-R. Based on this recommendation, three additional recommendations were drafted and approved, i.e., Functionalities, 60/76GHz short-range radar and 5.8GHz dedicated short-range communication.

Among these recommendations, the one on 5.8GHz dedicated short-range communication (DSRC) in Japan and European countries including Italy was approved. The DSRC in Japan was targeted at ETC at that time. In 2002, the amendment of the recommendation was approved reflecting the new DSRC in Japan which was based on the ordinance of the Ministry of Internal Affairs and Communications in 2001.

Presently, a proposal is provided to reflect the ASL (Application Sub Layer) established in Japan on the recommendation for 5.8GHz dedicated short-range communication. This additional revision has just been approved by SG8. The next-generation ITS radiocommunication requested by ISO/TC204, North America and Korea and further, millimeter-wave for ITS newly proposed by Japan are being studied.

The history of preparing recommendations for ITS and the outline of recommendation documents already approved are shown below.

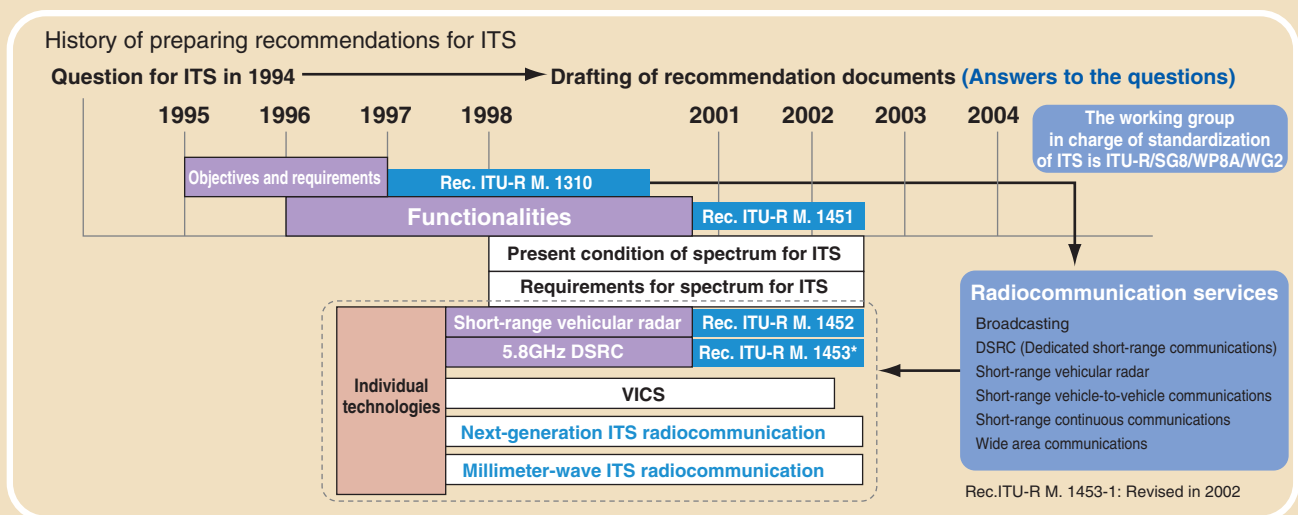

### Outline of recommendation documents

Name of the document	Document number	Content
Objectives and Requirements	ITU-R M.1310	Document on architecture of ITS radiocommunication which provides the objectives and requirements of ITS
Functionalities	ITU-R M.1451	Positioning each function of ITS against specific communication services
Low power short-range vehicular radar equipment at 60 GHz and 76 GHz	ITU-R M.1452	Describing technical standards and parameter of low power collision-prevention radar at 60GHz and 76GHz
Dedicated Short Range Communications (DSRC) at 5.8 GHz	ITU-R M.1453	Recommendation for dedicated short-range communications in 5.8GHz band comprising active method in Japan, passive method in Europe and high data-rate passive method in Italy; In 2002, the recommendation was revised according to promotion of high data rate of DSRC in Japan. Further, examination is progressing toward an additional revision reflecting ASL in Japan.

# Theme for Standardization List of working items for ISO/TC204 and their developing stages(as of February 2005)

WG	ISO Number	Title	Developing stages						Publications
			PWI	NP	WD	CD	DIS	FDIS	
1	14812	Glossary of Standard Terminologies for the ITS Sector							(TR)
1	14813-1	Reference Model Architecture for the ITS Sector - ITS Fundamental Services				○			TS
1	14813-2	Reference Model Architecture for the ITS Sector - Core ITS Reference Architecture							TS
1	14813-3	Reference Model Architecture for the ITS Sector - Example Elaboration							TS
1	14813-4	Reference Model Architecture for the ITS Sector - Reference Model Tutorial							TS
1	14813-5	Reference Model Architecture for the ITS Sector - Requirements for Architecture Description in ITS Standards							TS
1	14813-6	Reference Model Architecture for the ITS Sector - Data Presentation Using ASN.1				○			TS
1	24531	Using XML (eXtensible Mark up Language) in Intelligent Transport System Standards, Data Registries and Data Dictionaries		○					
1	24532	Using CORBA (Common Object Request Broker Architecture) in Intelligent Transport System Standards, Data Registries and Data Dictionaries				○			
1	-	Using UML in ITS Standards	○						
1	-	Using Web Services (machine-machine delivery) for ITS service delivery	○						
1	-	Procedure for Developing ITS Deployment Plans Utilizing ITS System Architecture	○						
3	20452	Requirements and Logical Data Model for a PSF and an API used in ITS Database Technologies; and a Logical Data Organization for a PSF used in ITS Database				○			
3	17572	ITS Data Base Technology: Location Referencing				○			
3	22953	Extended Geographic Data Files			○				
3	-	Navigation System Application Programme Interface (API)	○						
3	-	Data Structures for Map Data Provision and Update in ITS Applications	○						
4	14814	RTTT - Automatic Vehicle and Equipment identification - Reference Architectures and Terminology						○	
4	14815	RTTT - Automatic Vehicle and Equipment identification - System Specifications						○	TS→(ISO)
4	14816	RTTT - Automatic Vehicle and Equipment identification - Numbering and Data Structures						○	TS→(ISO)
4	17261	RTTT - Intermodal Goods Transport - Reference Architectures and Terminology							(TS)
4	17262	RTTT - Intermodal Goods Transport - Numbering and Data Structures							TS
4	17263	RTTT - Intermodal Goods Transport - System Parameters							TS
4	17264	RTTT - Intermodal Goods Transport - Interfaces			○				
4	24534-1	AVI - ERI - Architecture				○			
4	24534-2	AVI - ERI - Operational Requirements				○			
4	24534-3	AVI - ERI - Vehicle Data				○			
4	24534-4	AVI - ERI - Secure Application Layer Using Asymmetric Techniques				○			
4	24534-5	AVI - ERI - Secure Application Layer Using Symmetric Techniques			○				
4	24535	AVI/AEI - Basic Electronic Registration Device				○			
5	14904	RTTT - Electronic Fee Collection (EFC) - Interface Specification for Clearing between Operators							TS
5	14907-1	RTTT - Electronic Fee Collection (EFC) - Test Procedures User and Fixed Equipment, Part 1: Description of Test Procedures							(TS)
5	14907-2	RTTT - Electronic Fee Collection (EFC) - Test Procedures User and Fixed Equipment, Part 2: EFC Application Conformance Tests Specification				○			
5	17573	RTTT - Electronic Fee Collection (EFC) - System Architecture for Vehicle Related to Transport Services							TS
5	17574	RTTT - Electronic Fee Collection (EFC) - Guideline for EFC Security Protection Profiles							TS
5	17575	RTTT - Electronic Fee Collection (EFC) - Application Interface Definition for Global Navigation Satellite Systems and Cellular Networks (GNSS/CN)				○			
7	17687	Data Dictionary and Message Sets for Electronic Identification and Monitoring of Hazardous Materials/Dangerous Goods Transportation					○		
7	24533	Data Dictionary and Message Set for Tracking of Freight and its Intermodal Transfer - Road Transport Information Exchanges				○			
8	17686	Public Transport Communications Interface Profile (TCIP)				○			
8	22951	Data Dictionary and Message Sets for Pre-emption and Prioritization Signal Systems for Emergency and Public Transport Vehicles (PRESTO)				○			
8	-	ITS Emergency Services Communications Interfaces	○						
8	-	Public Transport Interoperable Fare Management System - Part 1:Architecture (Joint Work Item with CEN Lead CEN WI 278179)	○	○					
8	-	Standard Numbering System for Public Transport Stops (re-activation)	○						
9	14827-1	Data Interfaces between Centres for Transport Information and Control Systems - Message Definition Requirement						○	
9	14827-2	Data Interfaces between Centres for Transport Information and Control Systems - DATEX-ASN Application						○	
9	15784-1	Data Exchange involving Roadside Modules : Part 1 Framework and overview Application Profile		○					
9	15784-2	Data Exchange involving Roadside Modules : Part 2 Application Profile - TMP		○					
9	15784-3	Data Exchange involving Roadside Modules : Part 3 Application Profile - Datex		○					
9	-	TICS - Integrated Transport Information, Management and Control - Data Dictionary - Data Dictionary	○						
9	-	TICS - Integrated Transport Information, Management and Control - Data Dictionary - Congestion monitor Use Case	○						
9	21707	Quality of Input Data for ITS Systems				○			

Note) Refer to P35 for ISO/TC204 International Standards established and published so far.

WG	ISO Number	Title	Developing stages						Publications
			PWI	NP	WD	CD	DIS	FDIS	
10	14819-3	TTI Messages via Traffic Message Coding - Part 3: Location Referencing for Alert-C							(ISO)
10	14819-4	TTI Messages via Traffic Message Coding - Part 4: Coding Protocol for RDS-TMC using ALERT-C with ALERT+							(TR)
10	14819-5	TTI Messages via Traffic Message Coding - Part 5: Location Referencing for ALERT+							(TR)
10	14819-6	TTI Messages via Traffic Message Coding - Part 6: Encryption and conditional access for the Radio Data System - Traffic Message Channel ALERT C coding					○		
10	14821	TTI Messages via Cellular Networks							TR
10	14822-1	Traffic and travel information - Medium range pre-information via DSRC - General specification - Part 1: downlink					○		
10	14822-2	Traffic and travel information - Medium range pre-information via DSRC - General specification - Part 2: uplink					○		
10	14823	TTI Messages via Media-independent Stationary Dissemination Systems					○		
10	15074	User Services Integration for Traffic and Traveller Message Lists			○				
10	18234-1~5	TTI over High Data-rate Broadcast Digital Bearers - Part1~Part5					○		(TS)
10	18234-6	TTI via Transport Protocol Experts Group (TPEG) data streams - Part 6: Location Referencing Applications (TPEG-Loc) CEN Lead					○		(TS)
10	24530-1	TTI via Transport Protocol Experts Group (TPEG) Extensible Markup Language (XML) Part 1: Introduction, common data types and tpegML					○		
10	24530-2	TTI via Transport Protocol Experts Group (TPEG) Extensible Markup Language (XML) Part 2: tpeg-locML					○		
10	24530-3	TTI via Transport Protocol Experts Group (TPEG) Extensible Markup Language (XML) Part 3: tpeg-rtmML					○		
10	24530-4	TTI via Transport Protocol Experts Group (TPEG) Extensible Markup Language (XML) Part 4: tpeg-ptiML					○		
10	-	TTI via Transport Protocol Experts Group (TPEG) Extensible Markup Language (XML) Part 5: tpeg-pkiML	○						
10	-	TTI via Transport Protocol Experts Group (TPEG) Extensible Markup Language (XML) Part 6: tpeg-cttML	○						
11	17384	Centrally Determined Route Guidance							(TR)
11	16914	On Board System Architecture - A Reference Layer Model							(PAS)
11	17684	ITS Message Set Translator to ASN.1 Formal Definitions							PAS
11	-	Data Concepts for Navigation and Route Guidance Services Adaptable to the Design Template for Navigation Message Sets	○						
14	15624	Roadside Traffic Impediment Warning Systems							TS
14	17361	Lane Departure Warning Systems							
14	17387	Lane Change Decision Aid Systems (LCDAS)							
14	-	Forward Collision Avoidance Assistance System (FCAAS)	○						
14	-	Extended Range Backing Aids System (ERBA)	○						
14	22178	Low Speed Following (LSF) Systems		○					
14	22179	Full Speed Range Adaptive Cruise Control (FSRA) Systems		○					
15	15627	Data Link Layer for Dedicated Short Range Communication - DSRC Layer 2			○				
15	15628	Application Layer for Dedicated Short Range Communication - DSRC Layer 7						○	
16	15662	TICS Wide Area Communication - Protocol Management Information						○	
16	21217	Wide Area Communications: CALM Architecture					○		
16	21212	CALM 2GC		○					
16	21213	CALM 3GC		○					
16	21214	CALM IR					○		
16	21215	CALM M5					○		
16	21216	CALM MM		○					
16	21210	CALM Networking Protocol					○		
16	22837	Configuration of Vehicle Probe Data for Wide Area Communication					○		
16	21218	CALM Common Station Manager (Lower Level SAPs)		○					
16	-	CALM Application Management	○						
16	-	Privacy - the Basic Principles for Probe Personal Data Protection	○						
16	-	CALM Spectrum Management	○						
16	-	CALM Media	○						

Note) The number of work items totals 83.

## Web sites related to ITS

### Representing organizations for ITS in countries and cities

ITS America	<a href="http://www.itsa.org/">www.itsa.org/</a>	ITS Munich	<a href="http://www.its-munich.de/">www.its-munich.de/</a>
ITS Australia	<a href="http://www.its-australia.com.au/">www.its-australia.com.au/</a>	ITS Netherlands(Connekt)	<a href="http://www.connekt.nl/">www.connekt.nl/</a>
ITSC(China)	<a href="http://www.itsc.com.cn/">www.itsc.com.cn/</a>	ITS Norway	<a href="http://www.its-norway.no/">www.its-norway.no/</a>
ITS Canada	<a href="http://www.itscanada.ca/">www.itscanada.ca/</a>	ITS Spain	<a href="http://www.itsespana.com/">www.itsespana.com/</a>
ITS Chile	<a href="http://www.itschile.cl/">www.itschile.cl/</a>	ITS Singapore	<a href="http://www.itssingapore.org.sg/">www.itssingapore.org.sg/</a>
ITS Czech Republic	<a href="http://www.its-cz.cz/">www.its-cz.cz/</a>	ITS South Africa	<a href="http://www.sasits.com/">www.sasits.com/</a>
ITS Finland	<a href="http://www.its-finland.fi/">www.its-finland.fi/</a>	ITS Sweden	<a href="http://www.its-sweden.com/">www.its-sweden.com/</a>
ITS France	<a href="http://www.itsfrance.net/">www.itsfrance.net/</a>	ITS Taiwan	<a href="http://www.its-taiwan.org.tw/">www.its-taiwan.org.tw/</a>
ITS Hong Kong	<a href="http://www.its-hk.org/">www.its-hk.org/</a>	ITS United Kingdom	<a href="http://www.its-uk.org.uk/">www.its-uk.org.uk/</a>
ITS India	<a href="http://www.itsindia.org/">www.itsindia.org/</a>	ITS Japan	<a href="http://www.its-jp.org/">www.its-jp.org/</a>
TTS Italia	<a href="http://www.ttsitalia.it/">www.ttsitalia.it/</a>	REAM (REAM Malaysia)	<a href="http://www.ream.org.my/">www.ream.org.my/</a>
ITS Korea	<a href="http://www.itskorea.or.kr/">www.itskorea.or.kr/</a>		

### Organizations involved in standardization of ITS (International)

AASHTO(America)	<a href="http://www.aashto.org/">www.aashto.org/</a>	ISO	<a href="http://www.iso.ch/">www.iso.ch/</a>
ANSI(America)	<a href="http://www.ansi.org/">www.ansi.org/</a>	ITE	<a href="http://www.ite.org/">www.ite.org/</a>
APEC	<a href="http://www.apecsec.org.sg/">www.apecsec.org.sg/</a>	ITS Standards(America)	<a href="http://www.its-standards.net/">www.its-standards.net/</a>
ASECAP	<a href="http://www.asecap.com/">www.asecap.com/</a>	ITU	<a href="http://www.itu.int/">www.itu.int/</a>
ASTM(America)	<a href="http://www.astm.org/">www.astm.org/</a>	JTC1	<a href="http://www.jtc1.org/">www.jtc1.org/</a>
CEN(Europe)	<a href="http://www.cenorm.be/">www.cenorm.be/</a>	NEMA(America)	<a href="http://www.nema.org/">www.nema.org/</a>
CEN/TC278(Europe)	<a href="http://www.nen.nl/cen278/">www.nen.nl/cen278/</a>	OMG	<a href="http://www.omg.org/">www.omg.org/</a>
EIA(America)	<a href="http://www.eia.org/">www.eia.org/</a>	PIARC	<a href="http://www.piarc.org/">www.piarc.org/</a>
ERTICO(Europe)	<a href="http://www.ertico.com/">www.ertico.com/</a>	SAE International	<a href="http://www.sae.org/">www.sae.org/</a>
ETSI(Europe)	<a href="http://www.etsi.org/">www.etsi.org/</a>	TEN-T(Europe)	<a href="http://www.ten-t.com/">www.ten-t.com/</a>
FHWA(America)	<a href="http://www.fhwa.dot.gov/">www.fhwa.dot.gov/</a>	TIA(America)	<a href="http://www.tiaonline.org/">www.tiaonline.org/</a>
IEC	<a href="http://www.iec.ch/">www.iec.ch/</a>	US-DOT(America)	<a href="http://www.dot.gov/">www.dot.gov/</a>
IEEE	<a href="http://www.ieee.org/">www.ieee.org/</a>		

### Ministries and organizations involved in standardization of ITS (Japan)

National Police Agency	<a href="http://www.npa.go.jp/">www.npa.go.jp/</a>	Ministry of Internal Affairs and Communications	<a href="http://www.soumu.go.jp/">www.soumu.go.jp/</a>
Ministry of Economy, Trade and Industry	<a href="http://www.meti.go.jp/">www.meti.go.jp/</a>	Ministry of Land,Infrastructure and Transport	<a href="http://www.mlit.go.jp/">www.mlit.go.jp/</a>
Japanese Industry Standard Committee	<a href="http://www.jisc.go.jp/">www.jisc.go.jp/</a>	Universal Traffic Management Society of Japan	<a href="http://www.utms.or.jp/">www.utms.or.jp/</a>
Japan Standards Association	<a href="http://www.jsa.or.jp/">www.jsa.or.jp/</a>	The Society of Automotive Engineers of Japan	<a href="http://www.jsae.or.jp/">www.jsae.or.jp/</a>
Institution for Transport Policy Studies	<a href="http://www.jterc.or.jp/">www.jterc.or.jp/</a>	Japan Electronics and Information Technology Industries Association	<a href="http://www.jeita.or.jp/">www.jeita.or.jp/</a>
Highway Industries Development Organization	<a href="http://www.hido.or.jp/">www.hido.or.jp/</a>	Association of Radio Industries and Businesses	<a href="http://www.arib.or.jp/">www.arib.or.jp/</a>
Road Management Technology Center	<a href="http://www.hozen.or.jp/">www.hozen.or.jp/</a>	Organization for Road System Enhancement	<a href="http://www.orse.or.jp/">www.orse.or.jp/</a>
Advanced Cruise-Assist Highway System Research Association	<a href="http://www.ahsra.or.jp/">www.ahsra.or.jp/</a>	Japan Institute of Construction Engineering	<a href="http://www.jice.or.jp/">www.jice.or.jp/</a>
Japan Automobile Research Institute	<a href="http://www.jari.or.jp/">www.jari.or.jp/</a>	Japan Digital Road Map Association	<a href="http://www.drm.jp/">www.drm.jp/</a>
Vehicle Information and Communication System Center	<a href="http://www.vics.or.jp/">www.vics.or.jp/</a>	Japan Traffic Management Technology Association	<a href="http://www.tmt.or.jp/">www.tmt.or.jp/</a>
Database Promotion Center, Japan	<a href="http://www.dpc.or.jp/">www.dpc.or.jp/</a>	ITS Standardization Database	<a href="http://www.its-jp.net/ISODB/">www.its-jp.net/ISODB/</a>
ITS Info-Communications Forum	<a href="http://www.itsforum.gr.jp/">www.itsforum.gr.jp/</a>		



Published by: **Japan Automobile Research Institute**  
 1-1-30,SHIBADAIMON,MINATO-KU,TOKYO,105-0012,JAPAN  
 Tel.81-3-5733-7925 Fax.81-3-5473-0655  
 URL [Http://www.jari.or.jp](http://www.jari.or.jp)



Prepared by: **ITS Japan**  
 NIHONJYOSHIKAIKAN building 3F,2-6-8,SHIBAKOUEN,  
 MINATO-KU,TOKYO,105-0011,JAPAN  
 Tel.81-3-5777-1014 Fax.81-3-3434-1755  
 URL [Http://www.its-jp.org](http://www.its-jp.org)

This publication is prepared as a part of ITS Standardization Project commissioned to JARI by the Ministry of Economy, Trade and Industry, FY 2005.

ITS規格化 V05-1

